

# INSTALLATION INSTRUCTIONS

## Integris® 2001B Headwall System and Vertical Chase (with and without a Breaker Panel) From Hill-Rom

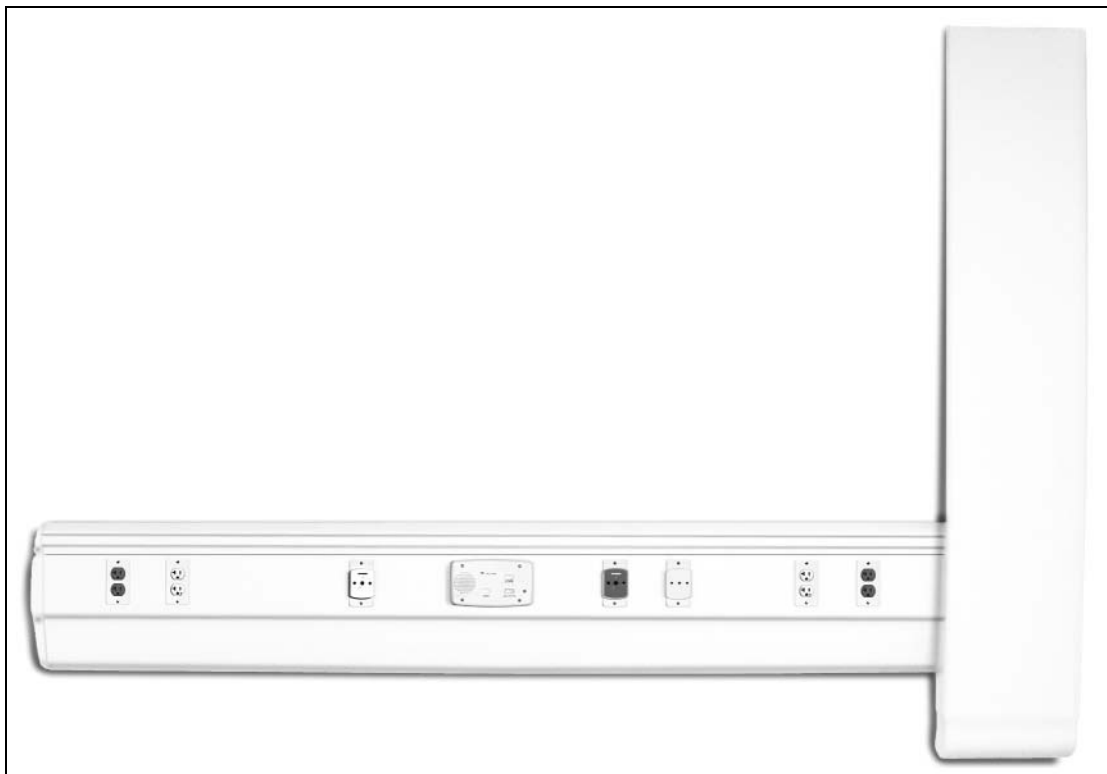

Product No. P2001B

For Parts or Technical Assistance  
Technical Support: (800) 445-3720  
Customer Service: (800) 445-3730  
Canada: (800) 267-2337  
International: Contact your distributor.  
[www.hill-rom.com](http://www.hill-rom.com)

is444re



# ***Integriss® 2001B Headwall System and Vertical Chase (with and without a Breaker Panel) Installation Instructions***

<b>Revision Letter</b>	<b>Pages Affected</b>	<b>Date</b>
Original Issue		May, 2000
A	All	August, 2000
B	1, 19, and 20	November, 2000
C	All	April, 2001
D	All	October, 2001
E	All	October, 2003

is444re

---

© 2003 by Hill-Rom Services, Inc. ALL RIGHTS RESERVED.

No part of this text shall be reproduced or transmitted in any form or by any means, electronic or mechanical, including photocopying, recording, or by any information or retrieval system without written permission from Hill-Rom Services, Inc. (Hill-Rom).

The information in this document is confidential and may not be disclosed to third parties without the prior written consent of Hill-Rom.

Sixth Edition

First Printing 2000

Printed in the USA

E-Z Ancor® is a registered trademark of Illinois Tool Works, Inc.

Hill-Rom® is a registered trademark of Hill-Rom Services, Inc.

Integris® is a registered trademark of Hill-Rom Services, Inc.

National Electrical Code® is a registered trademark of National Fire Protection Association, Inc.

NEC® is a registered trademark of National Fire Protection Association, Inc.

The information contained in this document is subject to change without notice. Hill-Rom makes no commitment to update or keep current, the information contained in this manual.

The only product warranty intended by Hill-Rom is the express, written warranty accompanying the bill of sale to the original purchaser. Hill-Rom makes no other warranty, express or implied, and in particular, makes no warranty of merchantability or fitness for a particular purpose.

Additional copies of this document can be obtained from Hill-Rom.

# ***Table of Contents***

Introduction . . . . .	1
Order of Installation . . . . .	3
Fastener Identification . . . . .	5
Determining the Wall/Construction Type . . . . .	7
Installing the Medical Gas Drops . . . . .	7
Installing the Vertical Chase with a Breaker Panel . . . . .	9
Installing the Hanger Bracket . . . . .	9
Installing the Vertical Chase . . . . .	11
Installing the Vertical Chase without a Breaker Panel . . . . .	13
Installing the Raceway . . . . .	16
Installing the Raceway Hanger Bracket(s) . . . . .	16
Positioning and Mounting a Single Raceway Section . . . . .	19
Mounting Multiple Raceway Sections . . . . .	21
Connecting the Gas Pipe . . . . .	22
Installing the Covers . . . . .	23
Installing the Raceway Gas Pipe Cover . . . . .	23
Installing the Splice Covers . . . . .	23
Installing the Covers on the Vertical Chase with a Breaker Panel . . . . .	23
Installing the Covers on the Vertical Chase without a Breaker Panel . . . . .	23

**NOTES:**

---

**Subject: Integris® 2001B Headwall System and Vertical Chase (with and without a Breaker Panel) Installation Instructions**

---

**Introduction**

This installation instruction sheet describes how to install the Integris® 2001B Headwall System raceway (A) and vertical chase (with a breaker panel) (B) or the vertical chase (without a breaker panel) (C) (see figure 1 on page 1).

**Figure 1. Integris® 2001B Headwall System and Vertical Chase**

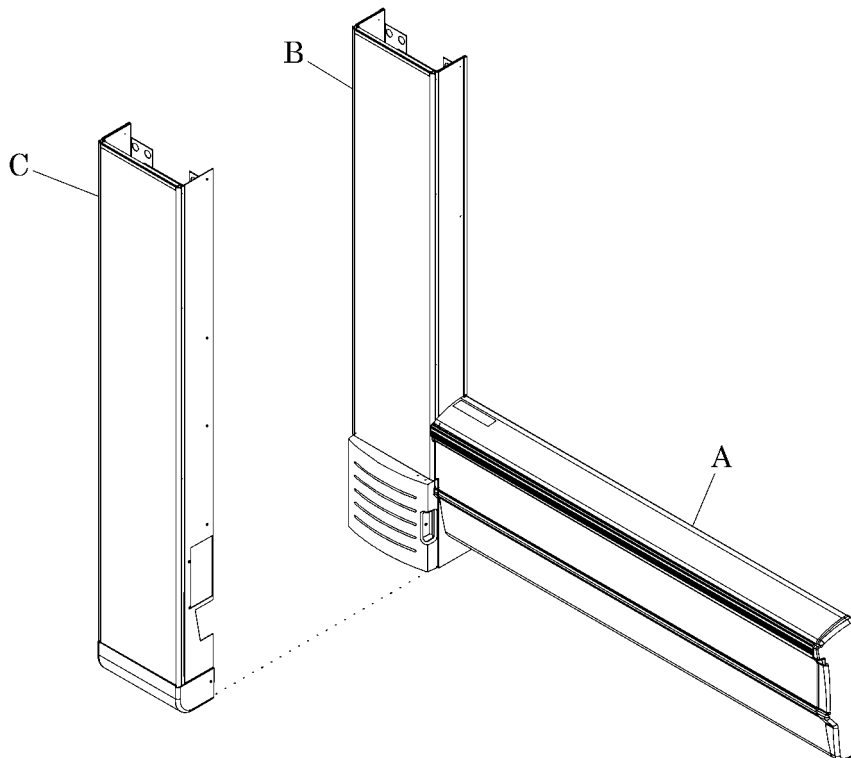

i444e001

Prior to installation, carefully read all of the installation instructions for the components you are installing.



**WARNING:**

For installation of the Integris® 2001B Headwall System (fire-rated/non-seismic), ensure that the walls are constructed of at least 20 gauge steel studs on 16" (41 cm) centerlines, and covered with a minimum of 5/8" (15.9 mm) dry wall. Failure to do so could result in the collapse of the Integris® 2001B Headwall System. Personal injury or equipment damage could occur.

Before installation of the headwall system components, the facility's medical gases and vacuum lines should have been run to the general location according to NFPA 99 and NFPA 70, National Electric Code®<sup>1</sup> (NEC®<sup>2</sup>).

Tools required:

- Standard drill/power screwdriver
- #2 phillips head screwdriver
- ¼" drill bit
- Medium screwdriver
- ½" spade bit
- Large screwdriver
- 7/8" spade bit
- 11/32" open end wrench
- 1" spade bit
- 5/16" hex head nutdriver
- Ratchet wrench
- 3/8" hex head nutdriver
- 9/16" deep socket with 3" extension
- Tape measure
- Level
- Chalk line
- Rubber mallet or block and hammer
- Ladder
- Adjustable wrench

Parts required:

(1)	205935	Splice cover top, complete
(1)	205934	Splice cover lower, 2001

Related Documents: [Integris® B Lite Rail Installation Instructions \(is443\)](#)

---

1. National Electric Code® is a registered trademark of National Fire Protection Association, Inc.  
2. NEC® is a registered trademark of National Fire Protection Association, Inc.

## Order of Installation

The numbered steps below correspond with the order of installation for the listed components.

1. Determine the type of wall (D) and construction type (see figure 2 on page 4).
2. Install the medical gas drops (E).
3. Perform **one** of the following:
  - To install the vertical chase (with a breaker panel) (B), install the vertical chase hanger bracket and the vertical chase with a breaker panel (B).
  - Install the vertical chase (without a breaker panel) (C).
4. To install the raceway (A), perform the following:
  - a. Install the raceway hanger bracket (F).
  - b. Position and install a single section of raceway (A).
  - c. Mount multiple sections of raceway (A).
  - d. Connect the gas pipe.
5. To install the covers, perform the following:
  - a. Install the gas pipe cover (G).
  - b. Install the vertical chase bottom cover (H).

**Figure 2. Component Identification**

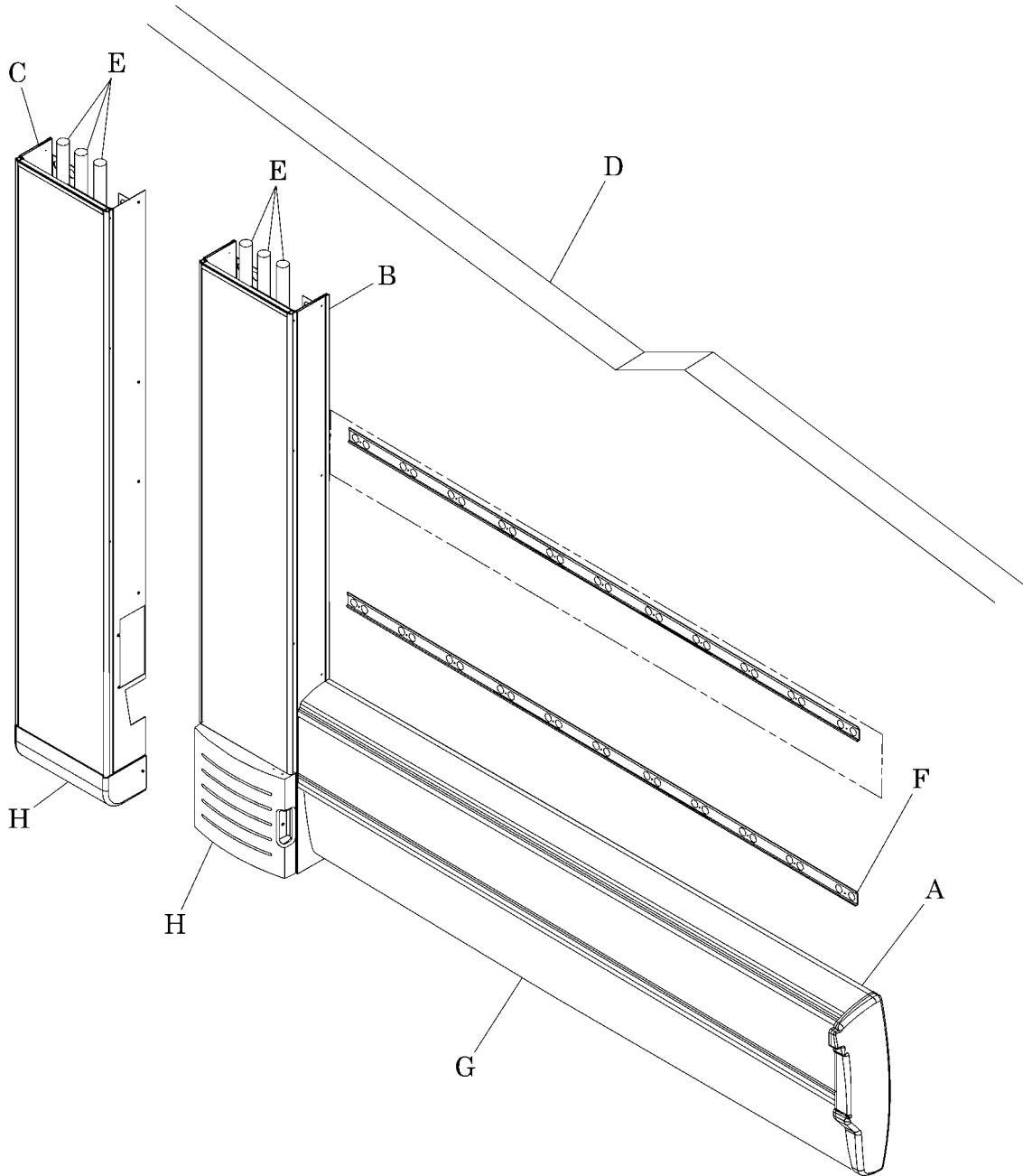

i444d002

## Fastener Identification

The fasteners in the following installation instructions are referred to by callout letter (see table 1 on page 5) and (see figure 3 on page 6).

**Table 1. Fastener Callout Letters**

<b>Callout Letter</b>	<b>Description</b>
I	Screw, #12-14 x 1½", self-drilling, hex head
J	Cup washer
K	Screw, 3/8"-16 x 3", slotted round
L	Toggle wing, 3/8"-16
M	Installation clip
N	Screw, #6 x 3/8", truss head
O	Screw, #12-14 x 1½", type AB, hex head
P	Transition pin
Q	#8-32 locknut
R	Screw, #6-20 x 3/8", flat head
S	Top splice cover
T	Screw, #8-32 x 1/2", pan head
U	E-Z Ancor® <sup>a</sup> screw anchor
V	Screw, #8-18 x 7/8", pan head
W	Lower splice cover
X	Screw, #10-32 x 1/2", pan head

a. E-Z Ancor® is a registered trademark of Illinois Tool Works, Inc.

**Figure 3. Fasteners**

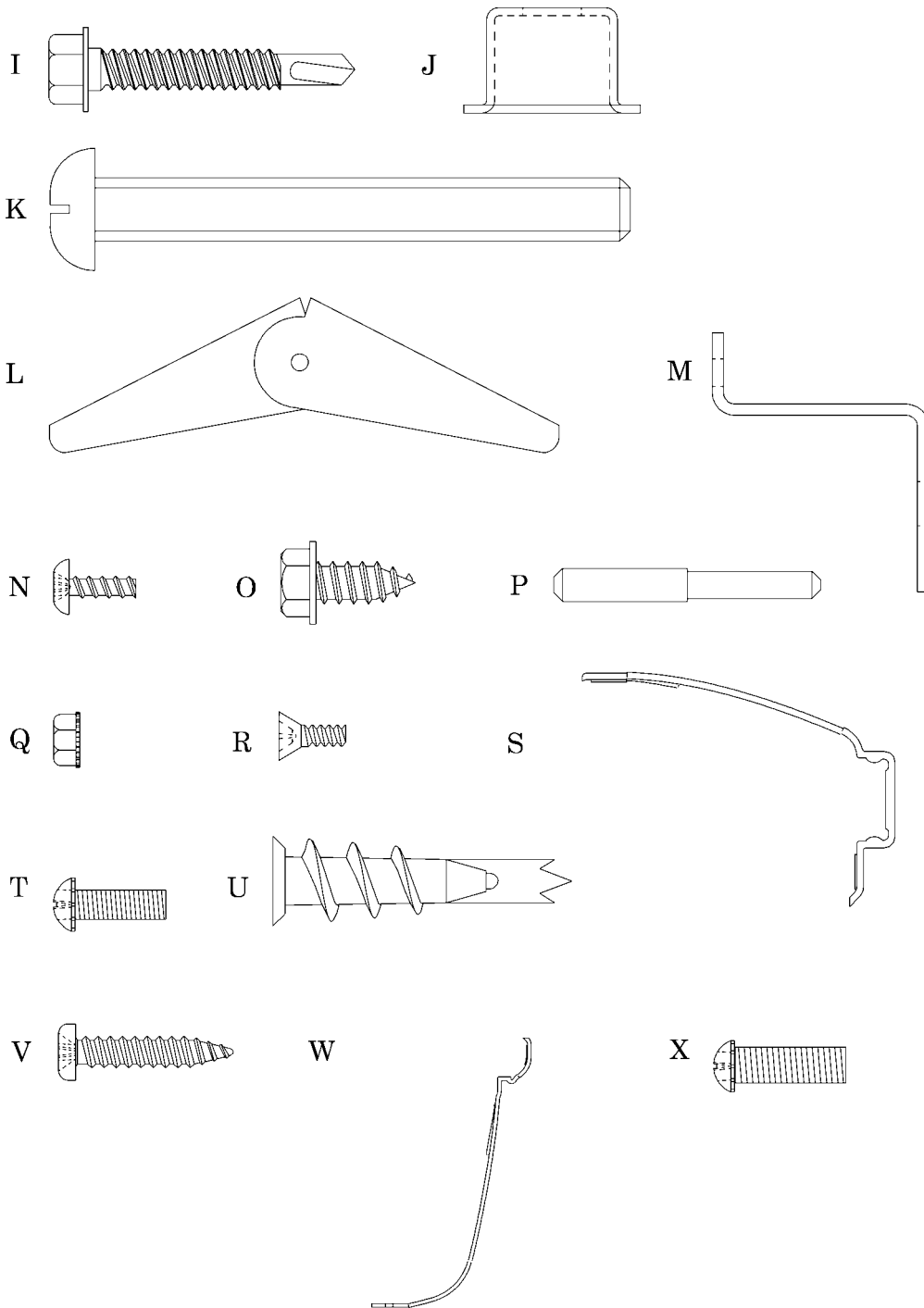

i444e003

## Determining the Wall/Construction Type



**WARNING:**

The installation method differs for each wall and construction type. Failure to determine the wall and construction type could result in personal injury or equipment damage.

1. Before proceeding, refer to the local or state building codes, and determine the type of wall (D) and construction type (see figure 2 on page 4):
  - **Seismic** walls are constructed to prevent damage from an earthquake.
  - **Non-seismic** walls are **not** constructed to prevent damage from an earthquake.
  - **Fire-rated** walls are constructed to prevent the spread of fire.
  - **Non-fire-rated** walls are **not** constructed to prevent the spread of fire.
2. Perform **one** of the following:
  - On **seismic** walls, install the wall backing plates according to the Office of Statewide Health, Planning, and Development (OSHPD)-approved drawings and the as-built drawings, and then go to “Installing the Medical Gas Drops” on page 7.

**NOTE:**

For **seismic** construction requirements, contact Hill-Rom Technical Support at 800-445-3720.

- On **non-seismic** walls (both fire and non-fire-rated), go to “Installing the Medical Gas Drops” on page 7.

## Installing the Medical Gas Drops

1. To locate the connections to the medical gas supplies, refer to the as-built drawings for the Integris® 2001B Headwall System.
2. Ensure that the connections to the medical gas supply are located in the center of the vertical chase (B) or (C), with the **oxygen** supply connection oriented closest to the raceway (A) (see figure 4 on page 8). If the connections are **not** properly located, a contractor must relocate them.
3. Install the medical gas service drops.

**Figure 4. Medical Gas Drops**

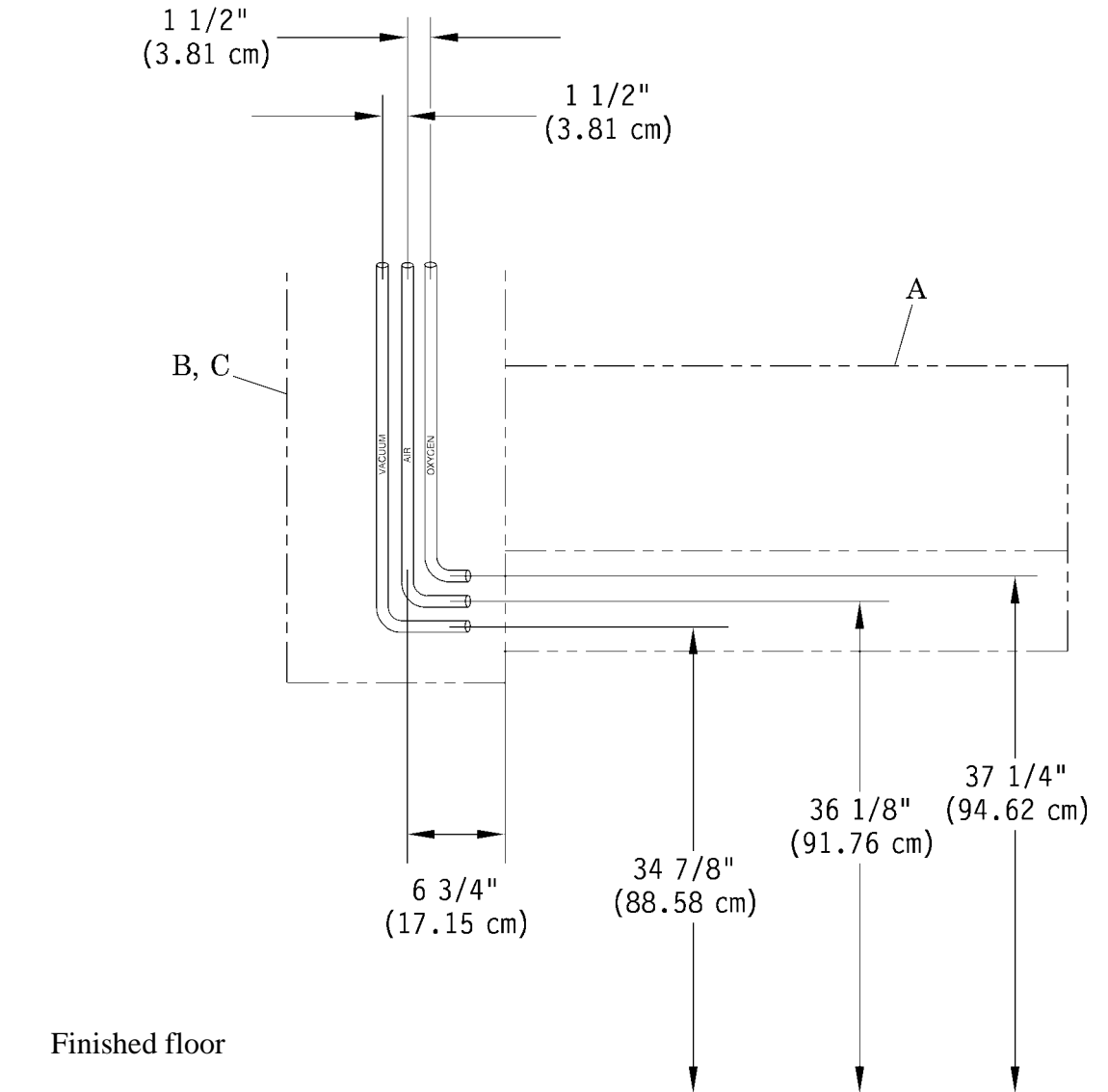

i444e017

4. Perform **one** of the following (see figure 2 on page 4):
  - On a vertical chase **with** a breaker panel (B), go to “Installing the Vertical Chase with a Breaker Panel” on page 9.
  - On a vertical chase **without** a breaker panel (C), go to “Installing the Vertical Chase without a Breaker Panel” on page 13.

## Installing the Vertical Chase *with* a Breaker Panel

### Installing the Hanger Bracket

**NOTE:**

Before installing a vertical chase with a breaker panel, you must install a chase hanger bracket.



**WARNING:**

The installation method differs for each wall and construction type. Failure to determine the wall and construction type could result in the collapse of the Integris® 2001B Headwall System. Personal injury or equipment damage could occur.

1. Ensure that the wall meets the required specifications:
  - On **non-seismic** construction, make certain the walls are constructed of at least 20 gauge steel studs on 16" (41 cm) centerlines and covered with a minimum of 5/8" (15.9 mm) dry wall.
  - On **seismic** construction requirements, contact Hill-Rom Technical Support at 800-445-3720.
2. If installing a vertical chase (B) against a corner wall, allow a minimum of 1/16" (1.6 mm) for the vertical trim between the vertical chase (B) and the side wall (see figure 5 on page 10).
3. For the location and height of the vertical chase (B), refer to the as-built drawings.
4. From the ceiling (Y), measure down the height of the vertical chase (B), and strike a level horizontal line (Z).
5. Locate the side of the vertical chase (B) on the end of raceway on the horizontal line (Z).
6. To locate the end of the chase hanger bracket (AA), measure 3/8" (9.5 mm) in from the side of the vertical chase (B).
7. Remove the chase hanger bracket (AA) from the bottom of the vertical chase (B), and save the fasteners.

**Figure 5. Vertical Chase with a Breaker Panel Hanger Bracket Installation**

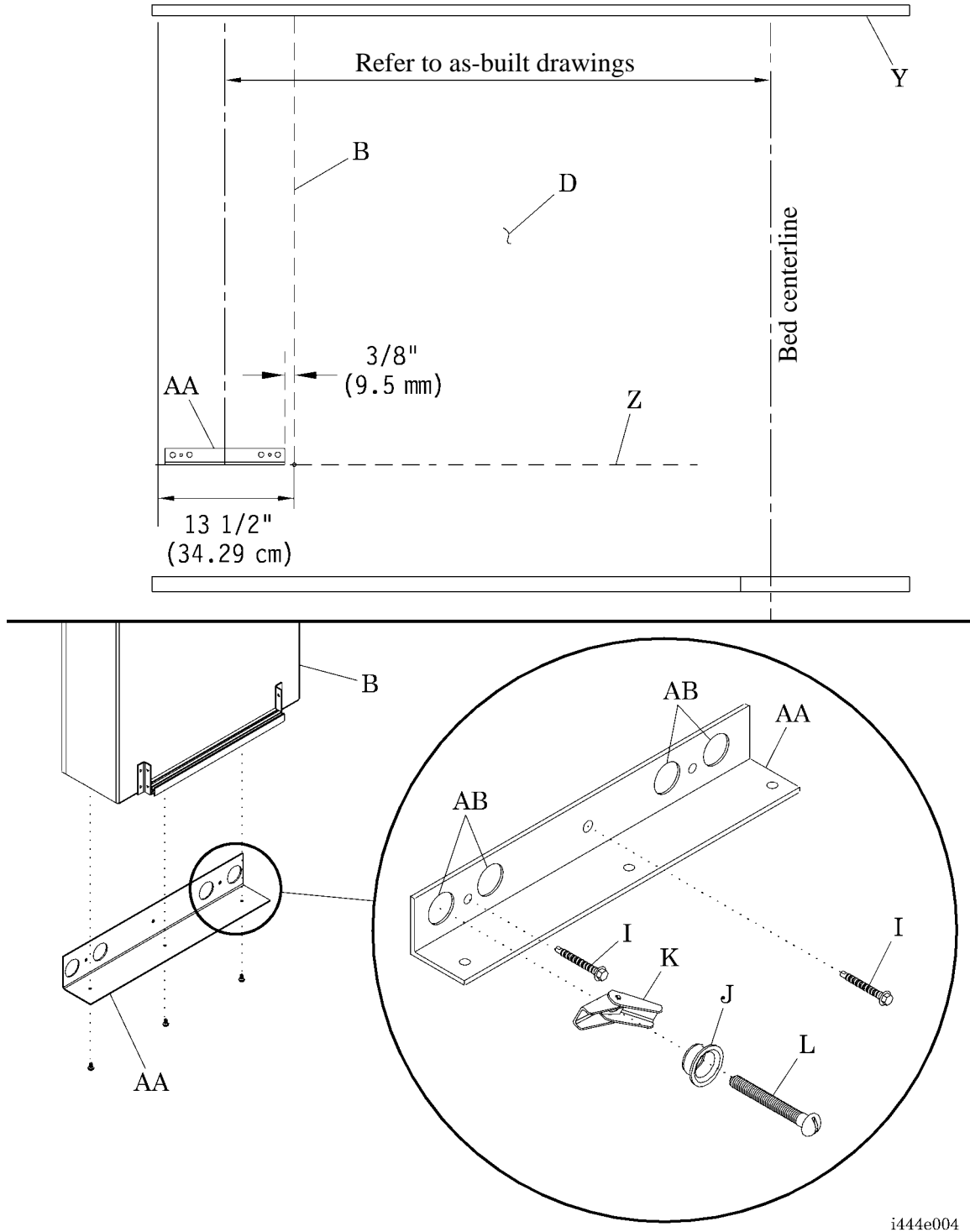

8. Align the bottom surface of the chase hanger bracket (AA) with the horizontal line (Z).
9. On **non-fire-rated** walls, perform the following:
  - a. On the wall (D), mark both pairs of 1" holes (AB) in the chase hanger bracket (AA).
  - b. At each pair of 1" (3 cm) holes (AB), drill only one of the 1" (3 cm) holes in the dry wall. If an obstruction or wall stud is encountered, use the alternate 1" (3 cm) hole (AB).
10. Perform **one** of the following:
  - On **non-seismic, non-fire-rated** walls, install the slotted round screw (K), toggle wings (L), and cup washers (J) to secure the chase hanger bracket (AA) to the wall.
  - On **fire-rated** and **seismic** walls, install the self-drilling hex head screws (I) to secure the chase hanger bracket (AA) to the wall stud or backing plate.

### **Installing the Vertical Chase**

1. At the raceway side of the vertical chase (B), remove the corner trim (AC) from the vertical chase (B) (see figure 6 on page 12).
2. Remove the finish cover (AD).
3. Lift the vertical chase (B) into position on the wall (D).
4. On **non-fire-rated** walls (D), perform the following:
  - a. On the wall (D), mark both pairs of 1" holes (AB) in the back of the vertical chase (B).
  - b. At each pair of 1" holes (AB), drill only one of the 1" holes in the dry wall. If an obstruction or wall stud is encountered, use the alternate 1" hole (AB).
5. Perform **one** of the following:
  - On **non-seismic, non-fire-rated** construction, install the slotted round screw (K), toggle wings (L), and cup washers (J) to secure the vertical chase (B) to the wall (D).
  - On **fire-rated** and **seismic** walls, install the self-drilling hex head screws (I) to secure the vertical chase (B) to the wall stud or backing plate.
6. Install the fasteners removed in step 7 of "Installing the Hanger Bracket" on page 9 to secure the bottom of the vertical chase (B) to the chase hanger bracket (AA).
7. Go to "Installing the Raceway" on page 16.

**Figure 6. Vertical Chase with a Breaker Panel Installation**

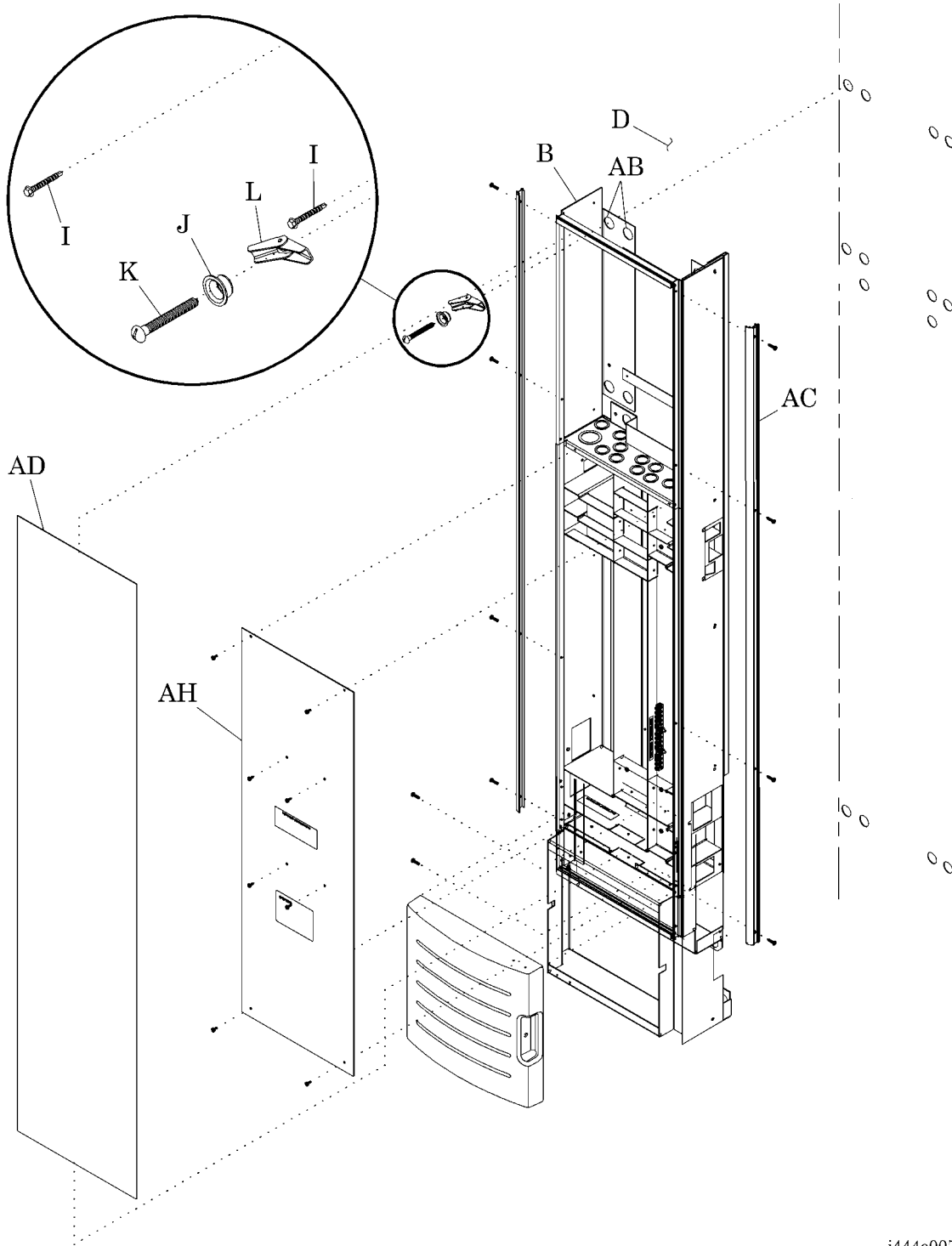

i444e007

## Installing the Vertical Chase *without* a Breaker Panel



**WARNING:**

The installation method differs for each wall and construction type. Failure to determine the wall and construction type could result in the collapse of the Integris® 2001B Headwall System. Personal injury or equipment damage could occur.

1. Ensure that the wall meets the required specifications:
  - On **non-seismic** construction, make certain the walls are constructed of at least 20 gauge steel studs on 16" (41 cm) centerlines and covered with a minimum of 5/8" (15.9 mm) dry wall.
  - On **seismic** construction requirements, contact Hill-Rom Technical Support at 800-445-3720.
2. If installing a vertical chase (C) against a corner wall, allow a minimum of 1/16" (1.6 mm) for the vertical trim between the vertical chase (C) and the side wall (see figure 2 on page 4).

3. For the location and height of the vertical chase (C), refer to the as-built drawings (see figure 7 on page 14).

**Figure 7. Vertical Chase without Breaker Panel Layout**

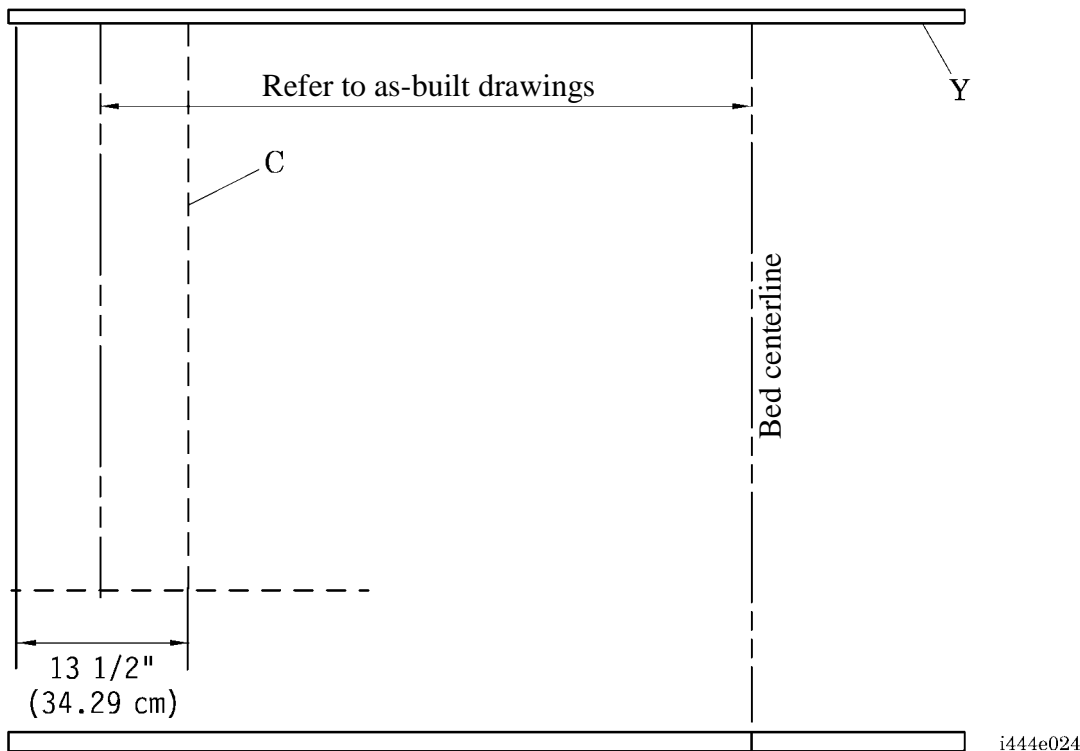

4. At the raceway side of the vertical chase (C), remove the corner trim (AC) from the vertical chase (C) (see figure 8 on page 15).
5. Remove the finish cover (AD).
6. Remove the bottom cover (H), and **retain** the screws (AE).
7. Lift the vertical chase (C) into position on the wall (D).
8. Ensure that the top of the vertical chase (C) is flush with the ceiling (Y) (see figure 7 on page 14).
9. On the wall (D), mark all six pairs of 1" (3 cm) holes (AB) in the backplate of the vertical chase (C) (see figure 8 on page 15).
10. Set the vertical chase without breaker panel (C) aside.
11. At each pair of holes (AB) marked on the wall (D), drill only one of the 1" (3 cm) holes in the dry wall. If an obstruction or wall stud is encountered, use the alternate marked hole.

**Figure 8. Vertical Chase without Breaker Panel Installation**

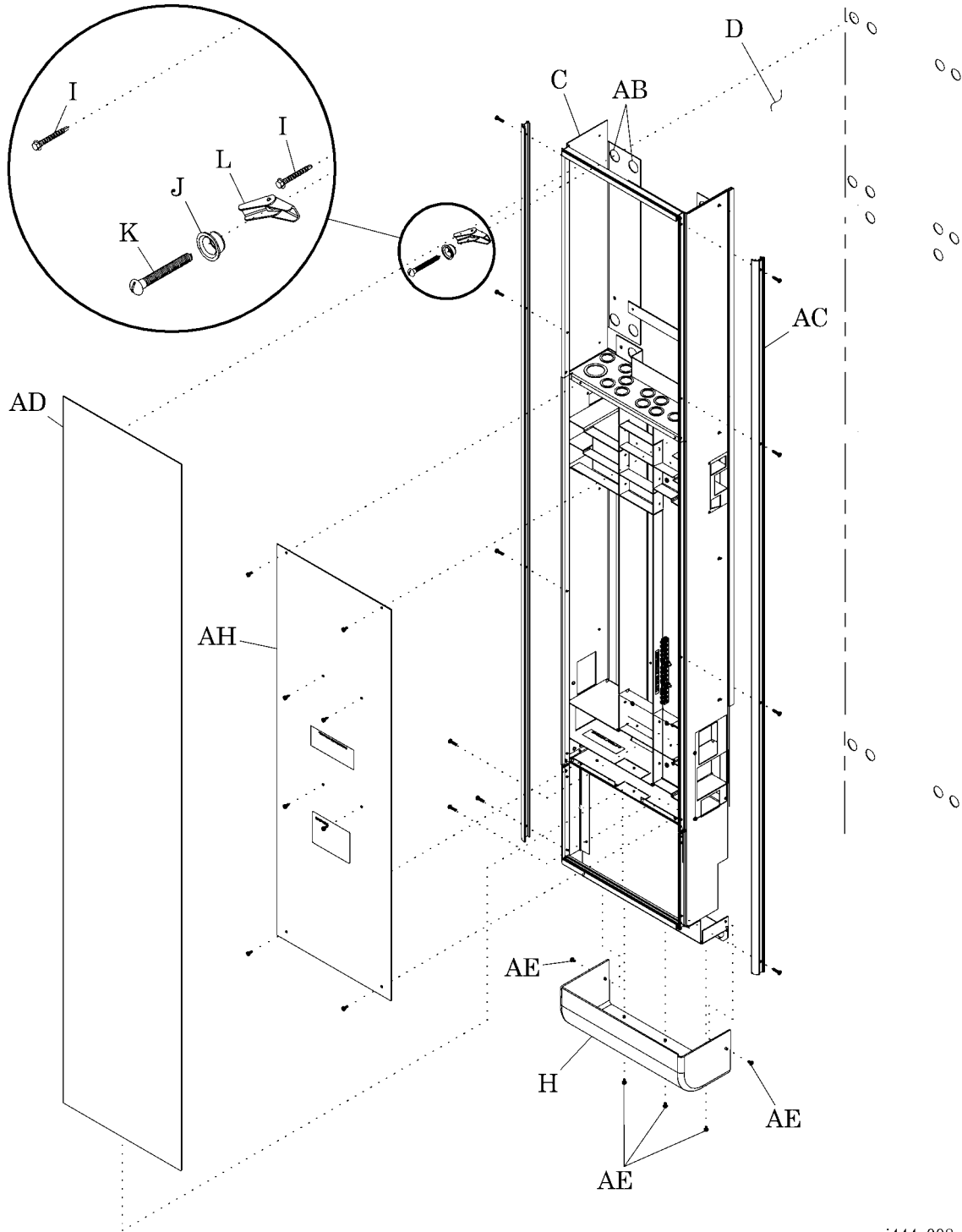

i444e008

12. Perform **one** of the following:

- On **non-seismic, non-fire-rated** walls, install the slotted round screw (K), toggle wings (L), and cup washers (J) to secure the vertical chase (C) to the wall (D).
- On **fire-rated** and **seismic** walls, install the self-drilling hex head screws (I) to secure the vertical chase (C) to the wall stud or backing plate.

## Installing the Raceway

### Installing the Raceway Hanger Bracket(s)

**NOTE:**

When installing a raceway, first install a raceway hanger bracket, and then connect the gas pipe.



**WARNING:**

Ensure that no electrical power is supplied to the facility wiring. Personal injury or equipment damage could occur.

**NOTE:**

When installing multiple headwalls, do not allow the breaks between the hanger brackets to align with the breaks between the headwall assemblies.



**WARNING:**

The installation method differs for each wall and construction type. Failure to determine the wall and construction type could result in the collapse of the Integris<sup>®</sup> 2001B Headwall System. Personal injury or equipment damage could occur.

1. Ensure that the wall meets the required specifications:

- On **non-seismic** construction, make certain the walls are constructed of at least 20 gauge steel studs on 16" (41 cm) centerlines and covered with a minimum of 5/8" (15.9 mm) dry wall.
- On **seismic** construction requirements, contact Hill-Rom Technical Support at 800-445-3720.

2. Locate the raceway hanger bracket (F) on the wall (D) by performing the following (see figure 9 on page 18):
  - On a vertical chase **with** a breaker (B), locate the bottom of the raceway hanger bracket (F) 18 11/16" (47.47 cm) from the bottom of the vertical chase (B).
  - For a vertical chase **without** a breaker (C), locate the bottom of the raceway hanger bracket (F) 19 1/8" (48.58 cm) from the bottom of the vertical chase (C).
3. If installing the optional Integris® B Lite Rail, ensure that the distance from the bottom of the Integris® B Lite Rail hanger bracket (AF) to the bottom of the raceway hanger bracket (F) is 25 13/16" (65.56 cm). Refer to the [Integris® B Lite Rail Installation Instructions \(is443\)](#).
4. On **non-fire-rated** walls, mark the pairs of 1" (3 cm) holes (AB) in the raceway hanger bracket (F) and, if necessary, the optional Integris® B Lite Rail hanger bracket (AF).
5. At each pair of marked holes (AB), drill only one of the 1" (3 cm) holes in the dry wall. If an obstruction or wall stud is encountered, use the alternate marked hole.
6. Perform **one** of the following:
  - On **non-seismic, non-fire-rated** walls, install the slotted round screw (K), toggle wings (L), and cup washers (J) to secure the raceway hanger bracket (F) to the wall (D).
  - On **fire-rated** and **seismic** walls, install the self-drilling hex head screws (I) to secure the raceway hanger bracket (F) to the wall stud or backing plate.



**CAUTION:**

When installing multiple hanger brackets, ensure that any additional hanger brackets are level with the first hanger bracket installed. Failure to do so could result in equipment damage.

7. Verify that the raceway hanger bracket (F) and, if necessary, the Integris® B Lite Rail hanger bracket (AF) are level.
8. If the wall (D) has waviness exceeding 1/16" (1.6 mm) per raceway hanger bracket (F), perform the following:
  - a. At the low spot(s), loosen the toggle wing (L).
  - b. Shim behind the raceway hanger bracket (F).
  - c. Tighten the toggle wing (L).

**Figure 9. Hanger Bracket Installation**

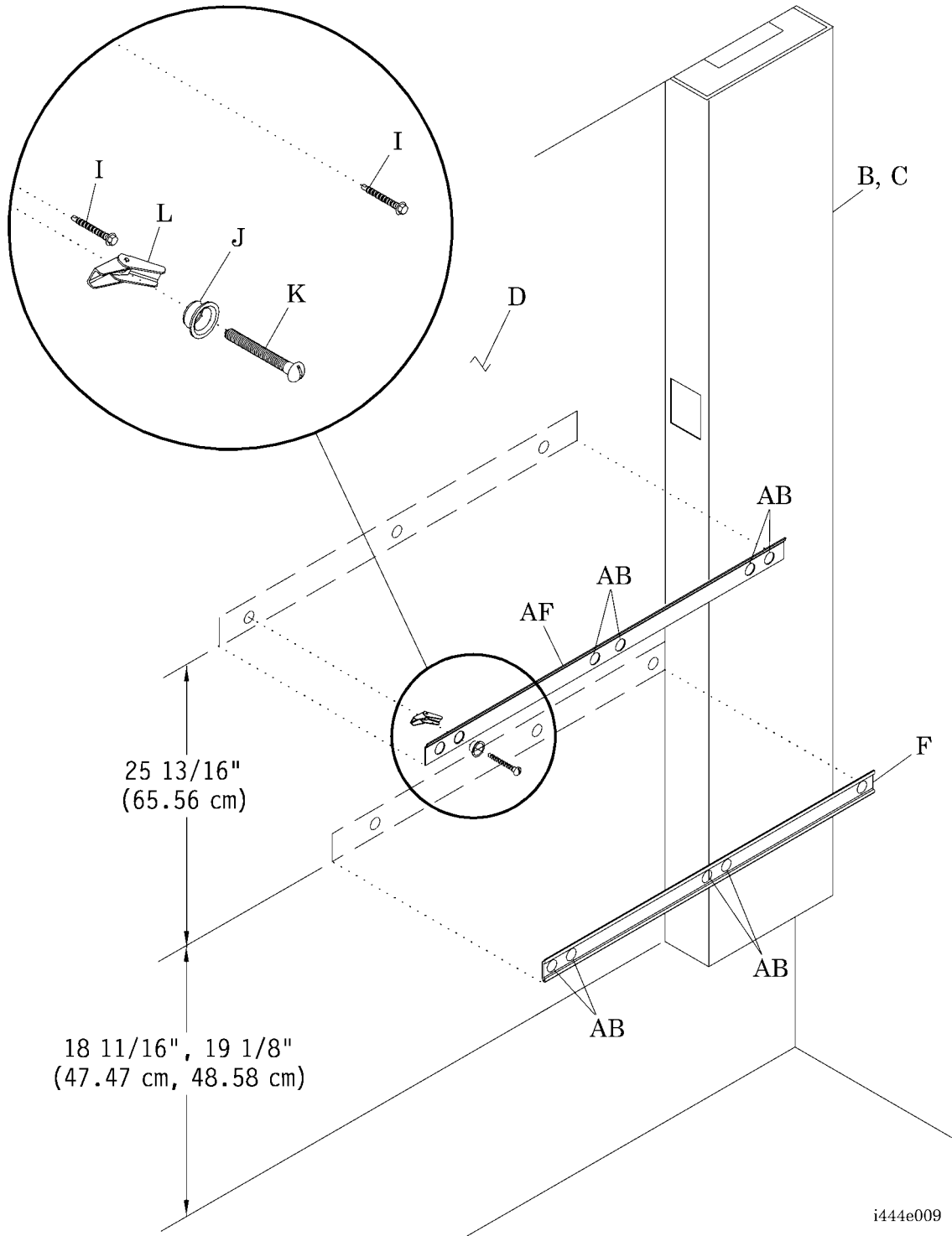

i444e009

9. Perform **one** of the following:
  - To install a single raceway, go to “Positioning and Mounting a Single Raceway Section” on page 19.
  - To install multiple sections of raceways, go to “Mounting Multiple Raceway Sections” on page 21.

### Positioning and Mounting a Single Raceway Section

**NOTE:**

The Integris® 2001B Headwall System **with** a vertical chase is shipped with only **one** pre-mounted raceway end cap.

1. Remove the screws (AG) that secure the gas pipe cover (G) (see figure 10 on page 19). **Retain** the screws (AG).

**Figure 10. Positioning and Mounting a Single Raceway Section**

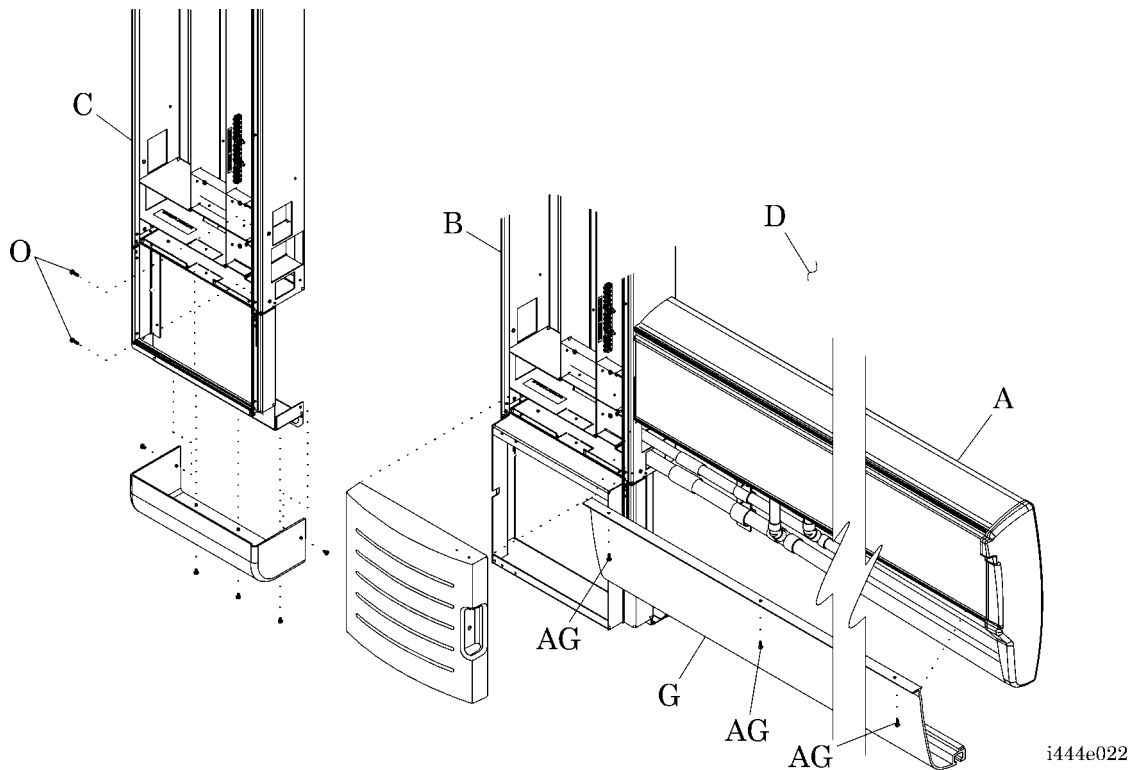

2. Remove and **retain** the gas pipe cover (G).
3. Position the raceway (A) on the raceway hanger bracket (F) (see figure 2 on page 4).
4. Remove the junction box cover (AH) from the vertical chase (B) (see figure 6 on page 12) or (C) (see figure 8 on page 15).

5. Adjust the raceway (A) laterally, routing the wiring from the end of the raceway (A) into the appropriate area of the junction box in the vertical chase (B, C) (see figure 10 on page 19).
6. Perform **one** of the following to secure the raceway (A) through the endplate and into the wall (D):
  - For **seismic** walls, install the self-drilling hex head screws (I) (see figure 3 on page 6).
  - For **non-seismic, non-fire-rated** construction, install the E-Z Ancor<sup>®1</sup> screw anchors (U) and the pan head screws (V), or install the slotted round screws (K), toggle wings (L), and cup washers (J) (see figure 3 on page 6).
7. Locate the installation clips (M), provided in the bag assembly, and align them with the wall studs.
8. Install the truss head screws (N) to secure the installation clips (M) (see figure 3 on page 6) to the raceway (A) (see figure 10 on page 19).
9. Install the self-drilling hex head screws (I) to secure the installation clips (M) (see figure 3 on page 6) to the wall (D) (see figure 10 on page 19).
10. Install two #12 hex head screws (O) through the vertical chase (B) or (C) and into the raceway (A).

**NOTE:**

Installation of the #12 hex head screws is required to meet National Electrical Code<sup>®2</sup> (NEC<sup>®3</sup>) Article 517, *Redundant Ground Requirements*.

11. Make the wiring connections.
12. Go to “Connecting the Gas Pipe” on page 22.

---

1. E-Z Ancor<sup>®</sup> is a registered trademark of Illinois Tool Works, Inc.

2. National Electrical Code<sup>®</sup> is a registered trademark of National Fire Protection Association, Inc.

3. NEC<sup>®</sup> is a registered trademark of National Fire Protection Association, Inc.

## Mounting Multiple Raceway Sections

**NOTE:**

Begin installation at the vertical chase, and install the section with a pre-mounted end cap last.

1. Hang the adjoining raceway (A) on the raceway hanger bracket (F) (see figure 11 on page 21).

**Figure 11. Mounting Multiple Raceway Sections**

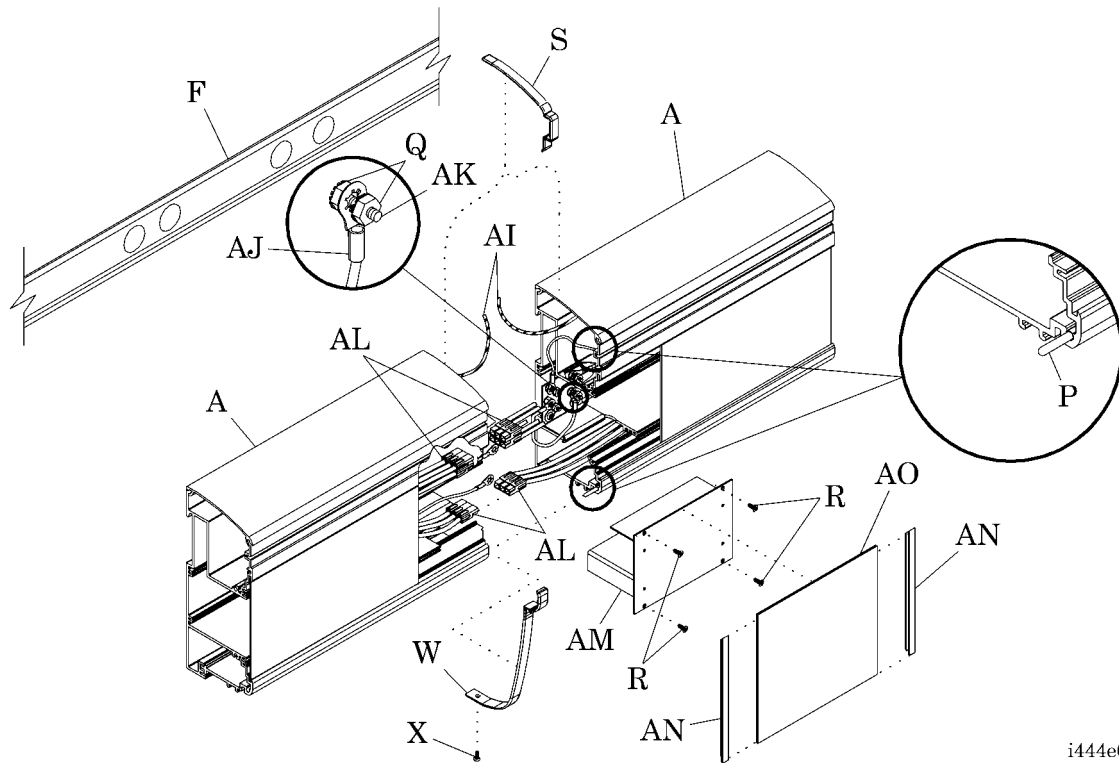

i444e012

2. Check for proper alignment of the transition pins (P) and the adjoining raceway (A).
3. Locate the two strings (AI) attached to the low voltage assemblies on the transition end of both the raceways (A), and tie the two strings (AI) together.
4. Join the raceways (A), and ensure that the adjoining ends are flush.
5. Connect the wiring between the raceways (A).
  - a. Pull the loose ends of wiring loops out of the ends of each raceway (A).
  - b. Sort the wires for **Standard Power**, **Critical Branch**, and **Communication**.
  - c. Install the locknuts (Q) to secure ground wires (AJ) on the posts (AK).



2. Using the facility-supplied couplings (AQ), connect the gas manifold (AP) to the corresponding facility gas lines (AR) for vacuum, medical air, and oxygen according to NFPA 99.
3. Braze the couplings (AQ), gas manifolds (AP), and facility gas lines (AR) according to NFPA 99. Refer to the *Standard for Health Care Facilities*.
4. Inspect the brazed joints for leaks.
5. Cover the gas pipe and the bottom of the raceway(s) (see “Installing the Covers” on page 23).

## **Installing the Covers**

### **Installing the Raceway Gas Pipe Cover**

1. Hook the lower edge of the gas pipe cover (G) on the endplates (see figure 10 on page 19).
2. Align the gas pipe cover (G) with the slots in the bottom of the raceway (A).
3. Install the screws (AG) based on the length of the gas pipe cover (G) and raceway (A).

### **Installing the Splice Covers**

1. Remove the protective backing from the adhesive on the top splice cover (S) and the lower splice cover (W) (see figure 11 on page 21).
2. Install the top splice cover (S) and the lower splice cover (W) over the joint where the raceways (A) meet.
3. Install the screw (X) to secure the lower splice cover (W) to the aluminum slide lock.

### **Installing the Covers on the Vertical Chase *with* a Breaker Panel**

1. Install the junction box cover (AH) (see figure 6 on page 12).
2. Install the finish cover (AD).
3. Install the corner trim (AC).

### **Installing the Covers on the Vertical Chase *without* a Breaker Panel**

1. Install the junction box cover (AH) (see figure 8 on page 15).
2. Install the finish cover (AD).
3. Install the corner trim (AC).
4. Install the bottom cover (H) by performing the following:

- a. Insert the tabs on the bottom cover (H) into the slot on the bottom trim.
- b. Install the five screws (AE) to secure the bottom cover (H).