

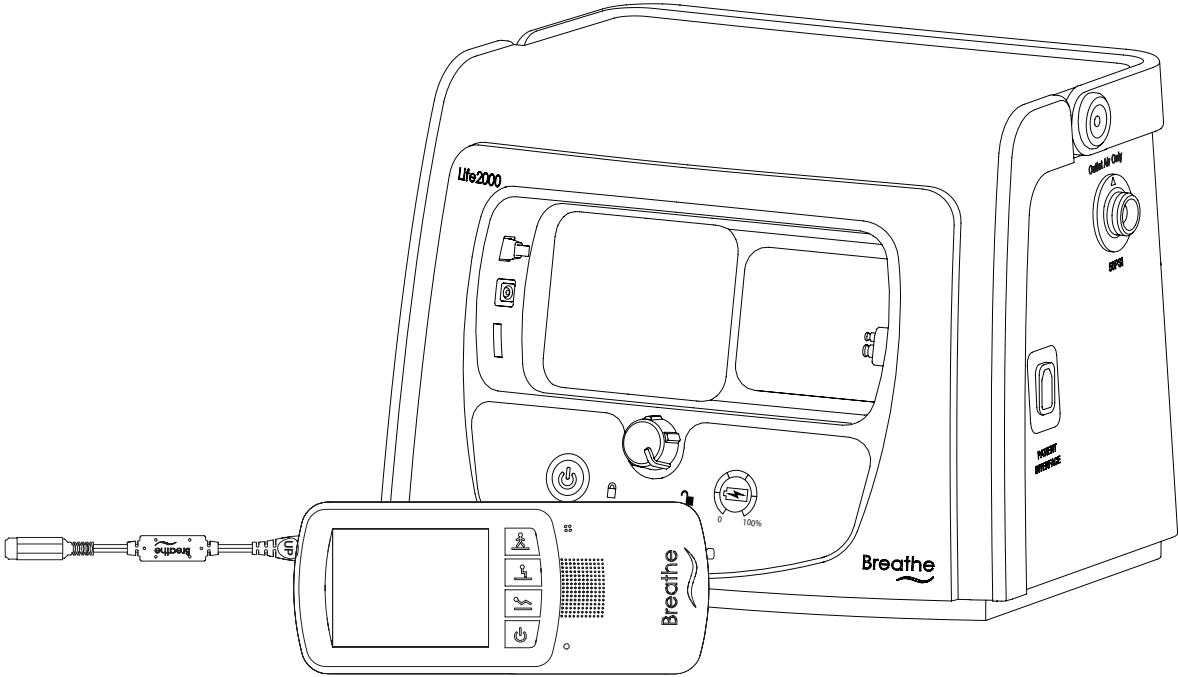

**Hillrom™**



# Quick Reference

Before using the Life2000® Ventilation System refer to the Life2000® Ventilation System Instructions for Use for a full list of warnings and cautions, detailed operating instructions, and additional information. This guide is not a substitute for the Instructions for Use. A copy of the Instructions for Use can be downloaded at <https://www.hillrom.com/en/products/life2000-system/>

**Life2000®** Ventilation System



# Table of Contents

Indications for Use .....	1
Safety Information .....	1
Package Content Overview.....	2
System Overview .....	3
Life2000® Ventilator Versions .....	3
Identifying the REF number.....	3
Life2000® Ventilator .....	4
Life2000® Compressor (Dockless).....	5
Life2000® Compressor (with Dock) .....	6
Setting Up & Charging Your Battery .....	7
Life2000® Compressor Setup .....	7
Charging the Ventilator .....	7
Life2000 Interfaces.....	8
The Breathe Pillows Entrainment Interface.....	8
Wearing the Breathe Pillows Entrainment Interface .....	8
Checking the Breathe Pillows Interface Positioning.....	8
Connecting The Life2000 Universal Circuit® Connector.....	9
System Setup .....	10
Extended Range Configuration .....	10
Stand Alone Configuration .....	11
Starting Therapy .....	11
Activity Buttons .....	11
Home Screen & Menu Overview.....	12
Home Screen .....	12
Menu Screen .....	13
Battery Information .....	14
Cleaning & Maintenance .....	15
Preventive Maintenance .....	15
Environmental Specifications .....	15
Cleaning the Breathe Pillows Entrainment Interface & Universal Circuit® Connector.....	16
Purging Interfaces using the Compressor .....	16
Alarms and Troubleshooting .....	17
Ventilator Alarms .....	17
How to Silence and Clear On-Screen Alarms .....	17
Ventilator Alarms .....	18
Compressor Alerts .....	19
Patient Setup Checklist.....	20

# Indications for Use

The Life2000® Ventilation System is intended to provide continuous or intermittent ventilatory support for the care of individuals who require mechanical ventilation.

The Life2000 Ventilation System consists of the Life2000 Ventilator and the Life2000 Compressor. The System is intended for use by qualified, trained personnel under the direction of a physician. Specifically, the System is applicable for adult patients who require the following types of ventilatory support:

- Positive Pressure Ventilation, delivered invasively (via ET tube) or non-invasively (via mask).
- Assist/Control mode of ventilation.

The System is suitable for use in home and institutional settings and is not intended for ambulance or air transportation.

## Safety Information

Please consult the Patient Instructions for Use for a full list of Tips, Notes, Cautions and Warnings. The Instructions for Use can be downloaded at <https://www.hillrom.com/en/products/life2000-system/> or contact Breathe Technologies at 877-698-1325 to request a copy by email or mail.

The operator of the ventilation system is responsible for reading and understanding the product manual before use.

### WARNINGS:

- **The Life2000 Ventilation System is a restricted medical device intended for use by qualified, trained personnel under the direction of a physician.**
- Off-label use of equipment is prohibited by law.
- Always have an alternate means of ventilation or oxygen therapy available.
- Any modifications to the Life2000 Ventilation System equipment and interfaces is prohibited.
- Breathe Pillows Entrainment Interface and Universal Circuit® connector are for single patient use only.
- Always inspect the interface equipment for cracks, breaks, kinks, or for any particular odor.
- Patient must secure interface equipment properly to avoid breathing distress and possible strangulation.

# Package Content Overview

## 1. Life2000® Ventilator (ventilator)

The ventilator can be used with the Life2000 Compressor or an alternate 50-PSI pressure source.

**NOTE:** Ventilators may not be configured with the Battery Charger Dongle.

## 2. Life2000® Compressor (compressor)

The compressor is an electropneumatic power unit that provides the ventilator with a continuous pressure source and is a charging station for the ventilator.

## 3. Belt clip for ventilator

The belt clip is used to secure the ventilator when it is used in wearable configurations.

## 4. Battery charger and AC power cord for the ventilator

The battery charger and AC power cord connect the ventilator to an AC power source.

## 5. External power supply and AC power cord for the compressor

The external power supply and AC power cord connect the compressor to an AC power source.

## 6. Ventilator Carry Pouch

Alternative to belt clip for securing the ventilator when using in wearable configurations.

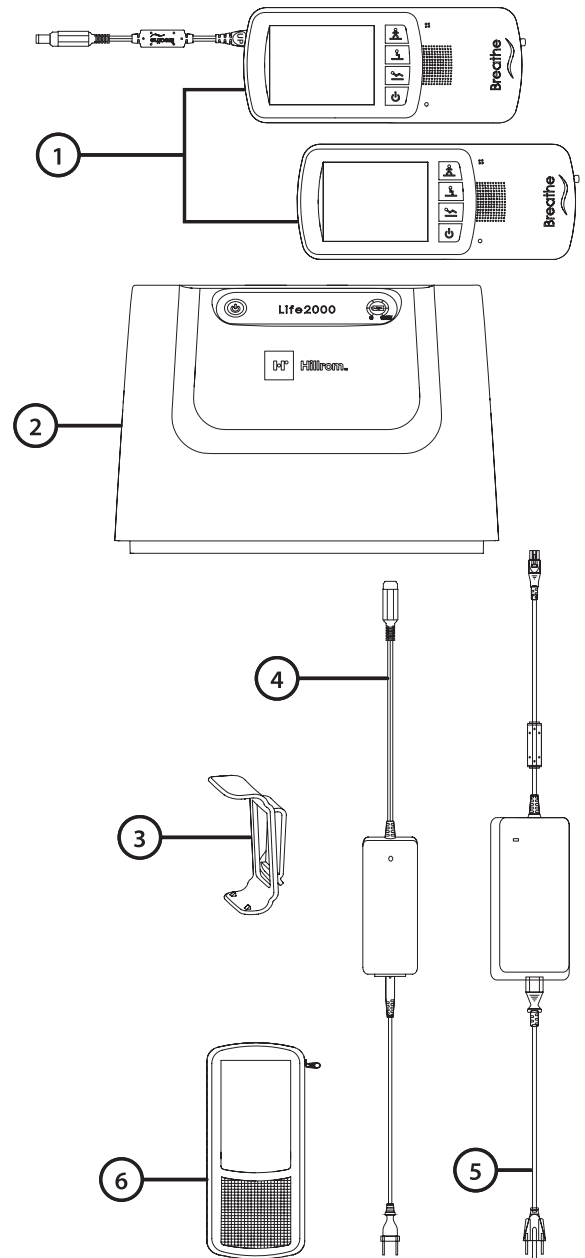

# System Overview

## Life2000® Ventilator Versions

There are two released ventilator versions of the Life2000 Ventilator. You will be able to identify the version of the ventilator based on the REF number.

The functionality of the ventilator's Communication Port, Battery Charge Icon, and System Alarms differ for each version of the ventilator. Please make sure to identify the REF number of the ventilator to ensure proper use of your system.

## Identifying the REF number

The REF number is located on the label on the back of the ventilator, see examples below.

Ventilator REF MS-01-0100,  
released prior to July x, 2019



Ventilator REF MS-01-0118,  
released after July x, 2019



# System Overview

## Life2000<sup>®</sup> Ventilator

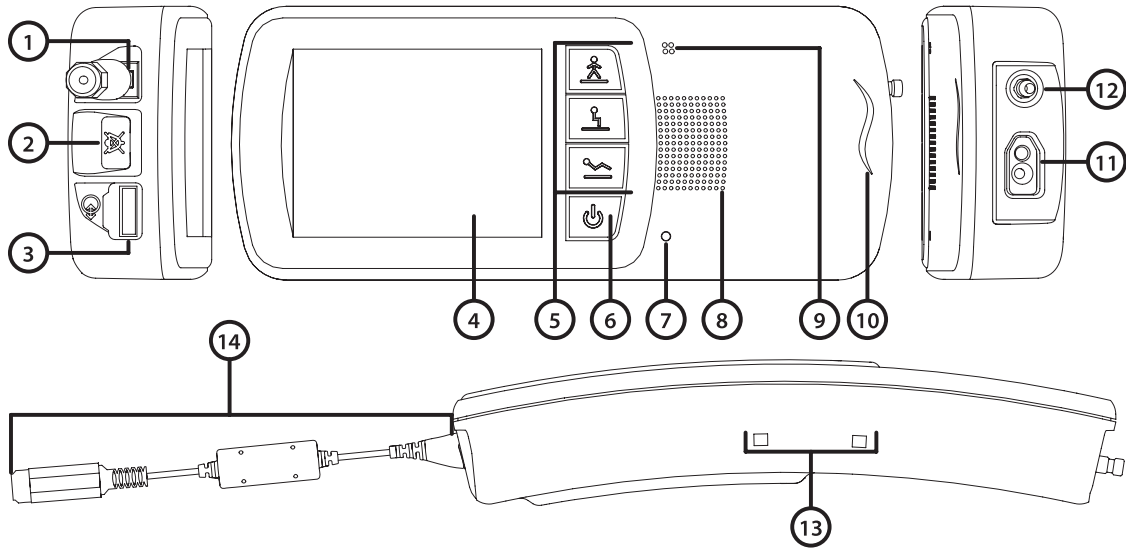

- |  |  |   |
|--|--|---|
| <p><b>1.</b> Battery charger connection</p> <p><b>2.</b> Silence Alarm button</p> <p><b>3.</b> Ventilator <b>REF MS-01-0100</b><br/>For manufacturer's use only</p> <p>Ventilator <b>REF MS-01-0118</b><br/>Communication port</p> | <p><b>4.</b> Touch screen</p> <p><b>5.</b> Activity buttons</p> <p><b>6.</b> Power button for ventilator</p> <p><b>7.</b> Power indicator light</p> <p><b>8.</b> Alarm speaker</p> | <p><b>9.</b> Backup alarm buzzer</p> <p><b>10.</b> Breath indicator light</p> <p><b>11.</b> Interface connection</p> <p><b>12.</b> Gas inlet connection</p> <p><b>13.</b> Belt clip sockets</p> <p><b>14.</b> Battery Charger Dongle*</p> |
|--|--|---|

**\*Ventilators may not be configured with the Battery Charger Dongle.**

# System Overview

## Life2000® Compressor (Dockless)

1. Power button for compressor
2. Battery charge status and indicator lights
3. Interface connection

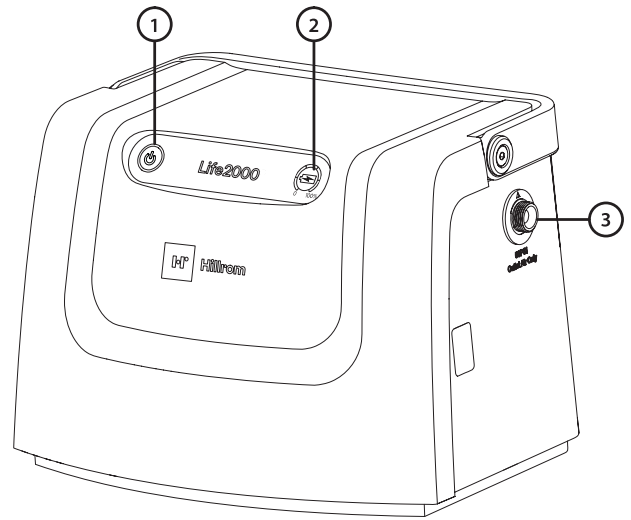

4. Handle
5. Air inlet and filter
6. Cooling filter cover
7. Cooling vents
8. Condensation tray
9. Power supply connection and cover
10. Alarm buzzer (internal)

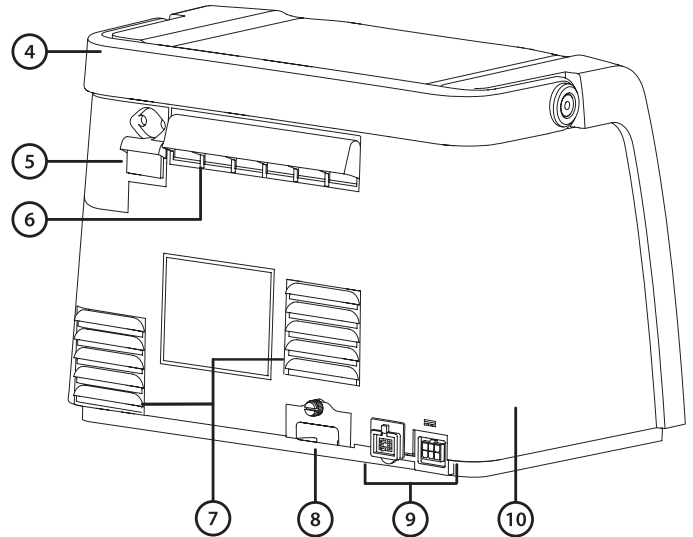



# System Overview

## Life2000® Compressor (with Dock)

1. Ventilator docking cradle
2. Power source indicator light
3. Power button for compressor
4. Locked icon (ventilator charging indicator light)
5. Locking knob
6. Unlocked icon
7. Battery charge status button
8. Battery charge indicator lights W and battery charge scale
9. Interface connection
10. Outlet fitting

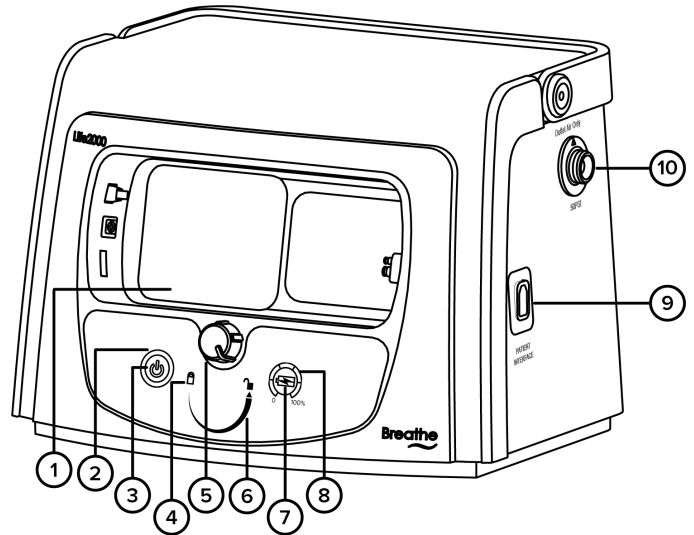

**NOTE:** Docking function is no longer applicable.

11. Handle
12. Air inlet and filter
13. Cooling filter cover
14. Cooling vents
15. Condensation tray
16. Power supply connection and cover
17. Alarm buzzer (internal)
18. Silence Alarm button

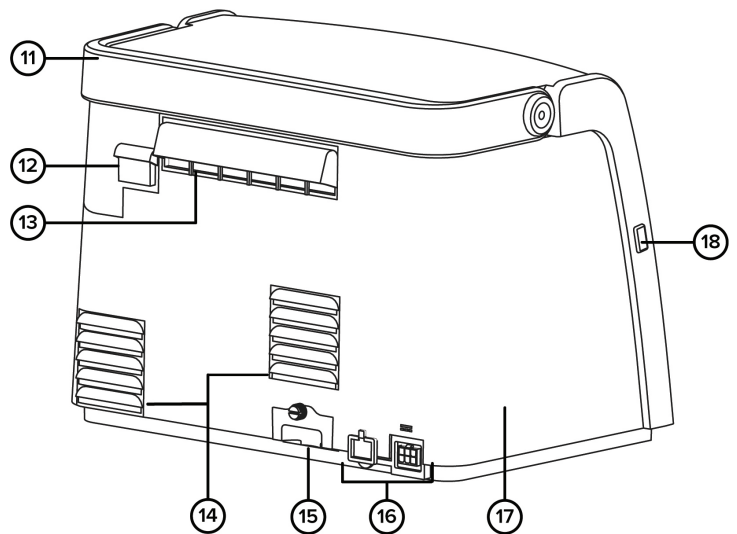

# Setting Up & Charging Your Battery

## Life2000® Compressor Setup

Position the compressor upright on a flat, level surface. Make sure that the cooling vents, cooling filter cover, and air inlet on the back of the compressor are not blocked, and there is sufficient clearance from surrounding objects. Protect the compressor from falling. The compressor should not be used adjacent to or stacked with other equipment.

**1.** Open the power supply connection cover.

**2.** Insert the AC power cord connector into the power supply connection on the back of the compressor until it clicks into place.

**3.** Connect the AC power cord to the compressor's external power supply and cord.

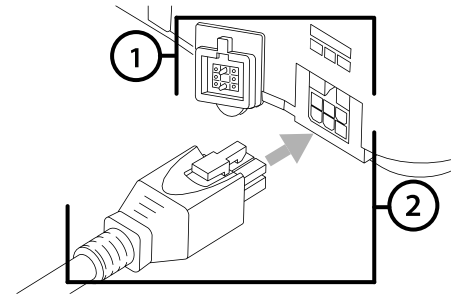

**4.** Connect the pronged end of the compressor's AC power cord to an AC power source.

**5.** Verify that the green LED indicator on the external power supply lights up to indicate the AC connection.

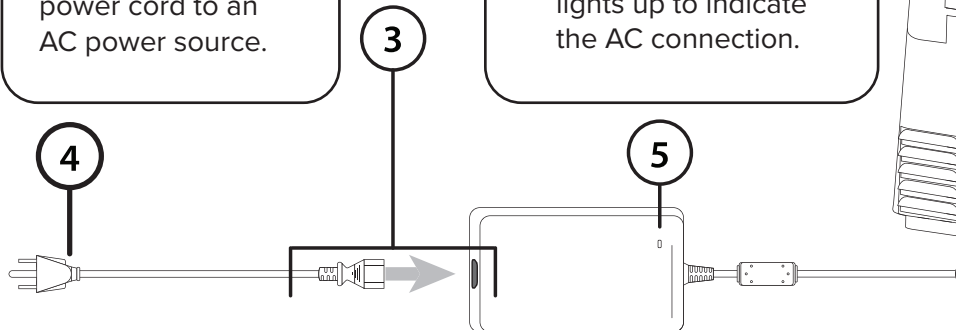
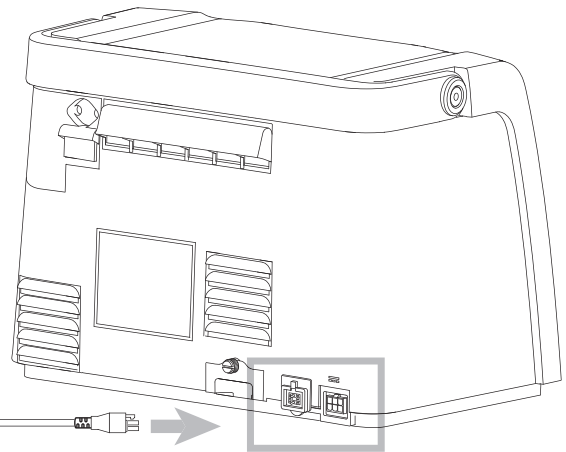

## Charging the Ventilator

**1.** Plug the ventilator AC power cord into the ventilator battery charger.

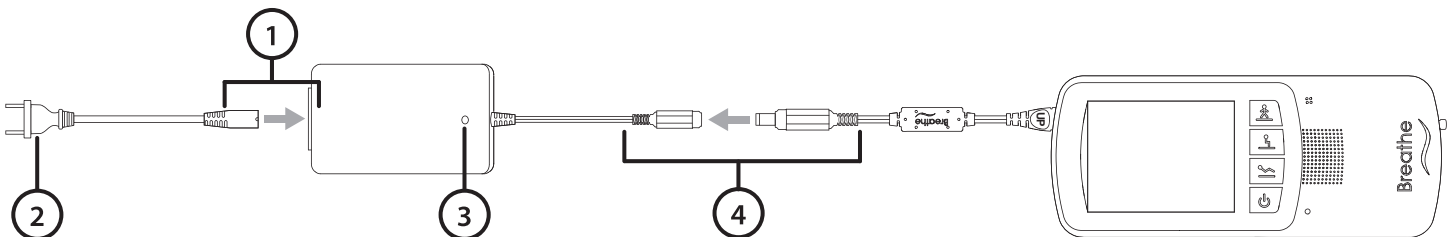

**2.** Connect the ventilator AC plug into an AC power source.

**3.** The ventilator battery charger indicator light turns on when connected to AC power.

**4.** Connect the battery charger cord to the battery charger dongle on the ventilator. For ventilators configured without battery charger dongle, connect the battery charger cord directly to the battery charger connector located on the ventilator.

**NOTE:** The ventilator can be used while the battery is charging.

# Life2000 Interfaces

## The Breathe Pillows Entrainment Interface

1. Nasal pillows (patient side)

2. Entrainment ports

3. Tube fit adjuster (cinch)

4. Interface tubing

5. Compressor or ventilator connector

6. Oxygen tubing connector

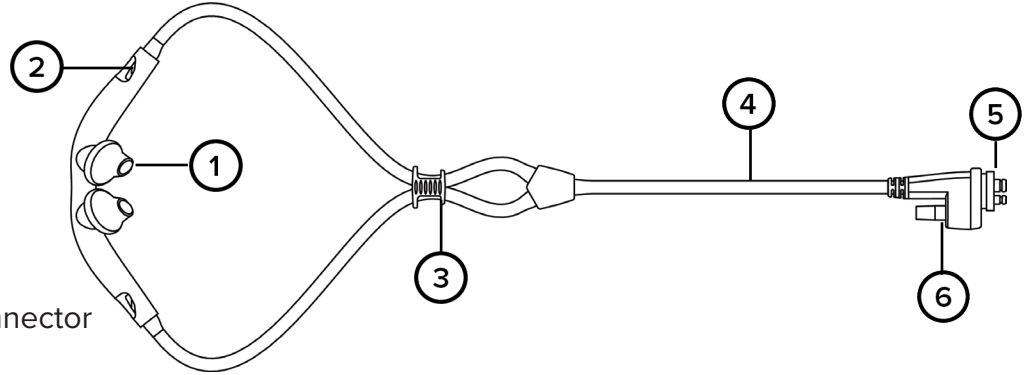

## Wearing the Breathe Pillows Entrainment Interface

1. Place the interface in front of the patient with the curve of the interface towards the patient's face and the entrainment ports facing up.

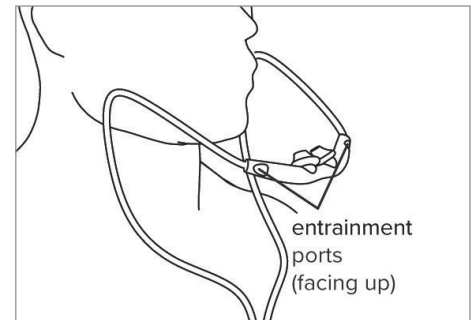

2. Loop the interface tubing over the ears and position the nasal pillows snugly inside the nostrils. Using the tube fit adjuster (cinch), adjust the tubing length under the chin so the interface is secured that snugly and comfortably

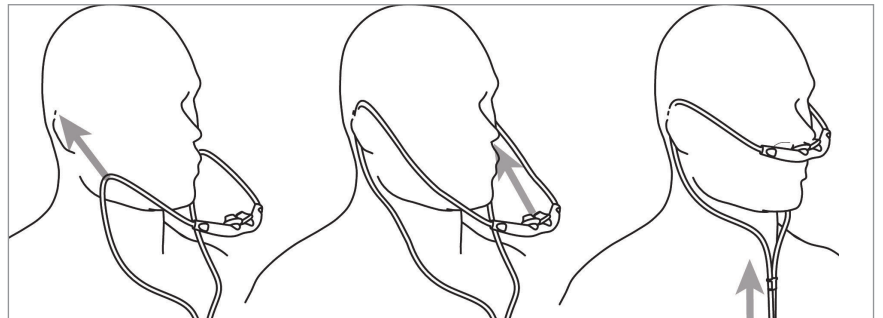

## Checking the Breathe Pillows Interface Positioning

The interface is placed correctly when:

- The interface pillows rest snugly inside the nostrils, as shown. The fit is comfortable
- The interface does not make breathing difficult.
- Air does not flow to the eyes, cheeks, or lips.
- Entrainment ports are not obstructed.

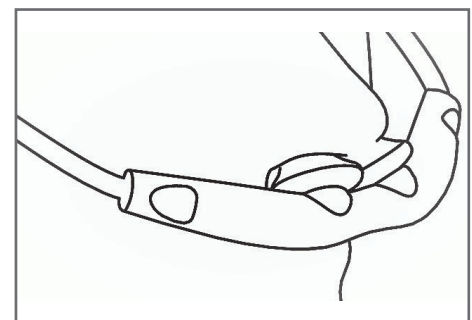

If any one of these conditions is not met, reposition the interface. If problems persist, try a different interface size.

# Life2000 Interfaces Cont'd.

## Connecting The Life2000 Universal Circuit® Connector

The Universal Circuit® connector is used to connect any commercially available non-invasive mask (full face, nasal, or pillows) to a ventilator or compressor.

The Universal Circuit® connector is only compatible with the Life2000 Ventilation System. When connecting the Universal Circuit® Connector, and oxygen therapy is required a third party Oxygen Adapter and Oxygen tubing will need to be connected.

### **WARNING:**

- Interfaces are designed for single-patient use. To prevent risk of cross-contamination use a new Universal Circuit® connector for each new patient. For the third-party mask or tube, refer to the user guide provided by the manufacturer.
- The interface, source gas supply hose, and power cords should be positioned to avoid restricting movement, causing a tripping hazard, or posing a strangulation risk.

### **CAUTION:**

- Hillrom recommends a 90-day replacement schedule for the Universal Circuit® connector.

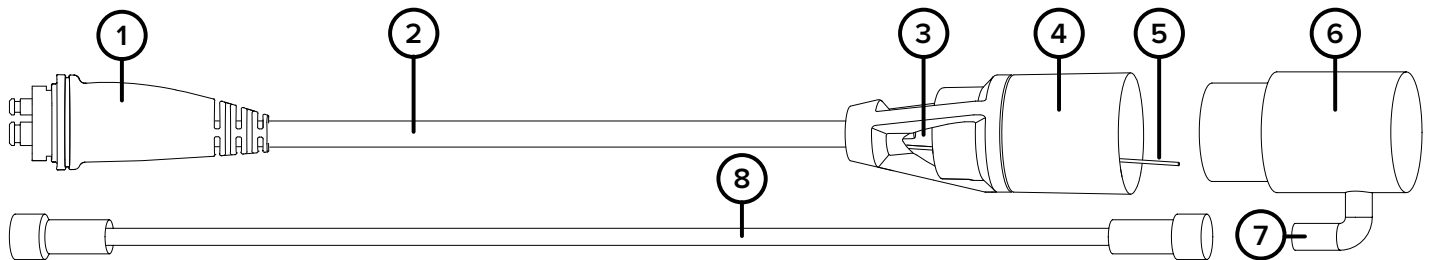

1. Compressor or ventilator connector

2. Interface tubing

3. Entrainment ports

4. Universal Circuit® Connector (patient side)

5. Sense Tube

6. Oxygen adapter (third party)

7. Barb connection

8. Oxygen tubing (third party)

**NOTE:** The interface assembly is packaged clean but not sterile. The Universal Circuit® connector does not need to be cleaned or sterilized prior to first use.

# System Setup

## Extended Range Configuration

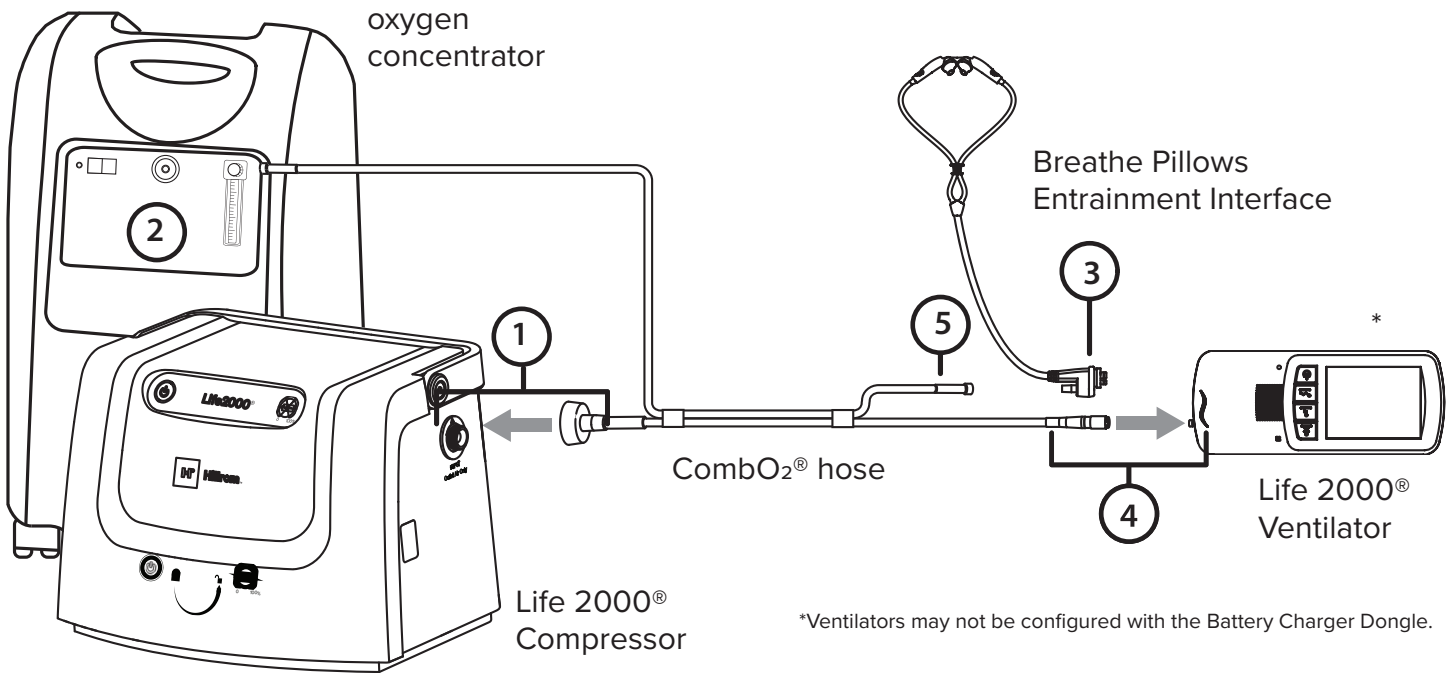

1. Ensure the ventilator is powered off.
2. Attach the outlet fitting connector on the CombO<sub>2</sub><sup>®</sup> hose to the outlet fitting on the compressor.
3. Connect the CombO<sub>2</sub><sup>®</sup> hose oxygen concentrator tubing to the oxygen concentrator (if available).
4. Connect the Breathe Pillows Entrainment Interface to the Life2000<sup>®</sup> Ventilator.
5. Connect the quick connect end on the CombO<sub>2</sub><sup>®</sup> hose to the ventilator by pushing the small quick connect end onto the gas inlet connection on the ventilator; when connected, the quick connect end will click into place.
6. Attach the CombO<sub>2</sub><sup>®</sup> oxygen tubing to the Breathe Pillows Entrainment Interface.

### **⚠ WARNING:**

The interface, source gas supply hose, and power cords should be positioned to avoid restricting movement, causing a tripping hazard, or posing a strangulation risk.

### **⚠ CAUTION:**

Use only a Hillrom source gas supply hose with the ventilation system. If an unauthorized source gas supply hose is used with the ventilation system, the system may be damaged.

# System Setup

## Stand Alone Configuration

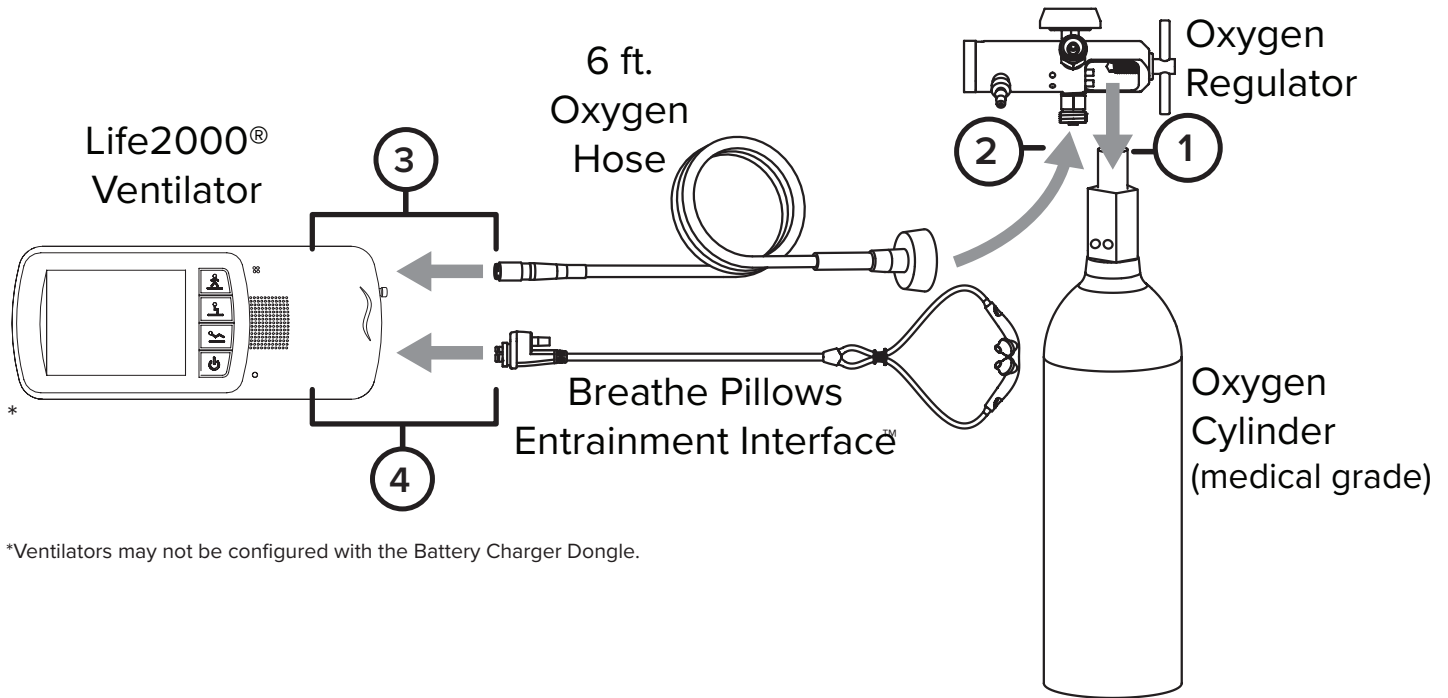

\*Ventilators may not be configured with the Battery Charger Dongle.

1. Attach the oxygen regulator (per the manufacturer's instructions for use) onto the oxygen cylinder.
2. Connect the oxygen hose to the Diameter Index Safety System (DISS) connector end of the regulator by turning it clockwise.
3. Connect the quick connect end on the oxygen hose to the ventilator by pushing the small quick connect end onto the gas inlet connection on the ventilator; when connected, the quick connect end will click into place.
4. Connect the Breathe Pillows Interface to the Life2000® Ventilator.

## Starting Therapy

### Activity Buttons

Each Activity Icon on a button in the Prescription Settings screen represents a prescription that can be programmed by a clinician and made available to the patient.

Each button on the Prescription Settings screen corresponds to an Activity Button on the ventilator.

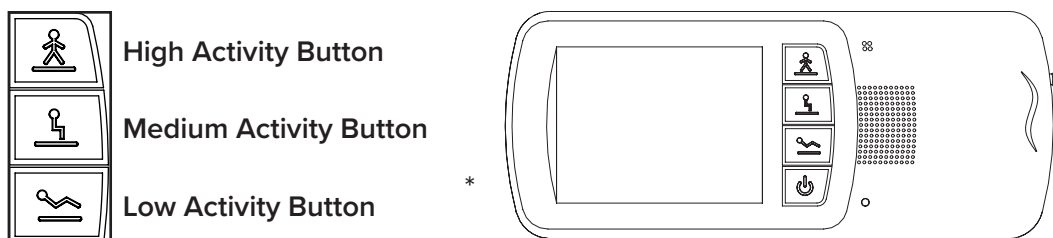

\*Ventilators may not be configured with the Battery Charger Dongle.

# Starting Therapy cont'd.

## Activity Buttons

When the ventilator is first powered on, you must select an Activity Button before a breath will be delivered.

One, two, or three Activity buttons may be available, as directed by a physician. Choose an Activity Button appropriate for your activity.

1. Ensure that the ventilator is powered on.
2. Ensure a pressure source (the compressor, an oxygen cylinder, or an oxygen wall source) is connected to the ventilator and turned on.
3. Press and hold an **Activity Button** until you hear a tone that indicates it is active. The touch screen will display the **Home Screen** and the ventilator will begin delivering therapy.

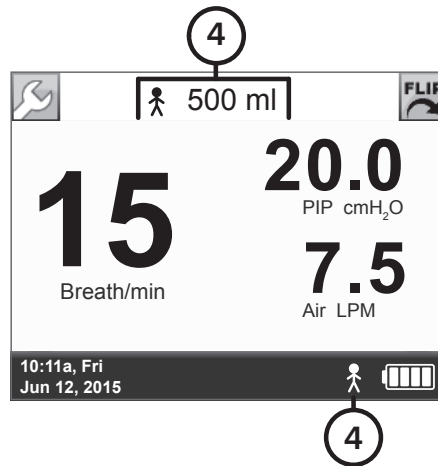

4. Confirm the selected **Activity Icon** is displayed at the bottom of the touch screen and the **icon** and **volume** are displayed at the top of the screen. The ventilator will begin ventilating using the chosen prescription parameters for the next breath.

## Home Screen & Menu Overview

### Home Screen

When the ventilator is powered on, it completes a self test and then displays the **Home Screen**. This screen indicates that the ventilator is **ready for use**.

When an **Activity Button** is selected on the ventilator, the Home Screen will display the breath rate per minute (**Breath/min** or **BPM**), **Peak Inspiratory Pressure** in centimeters of water pressure (**PIP cmH<sub>2</sub>O**), and gas flow rate in liters per minute (**Air LPM** or **O<sub>2</sub> LPM**).

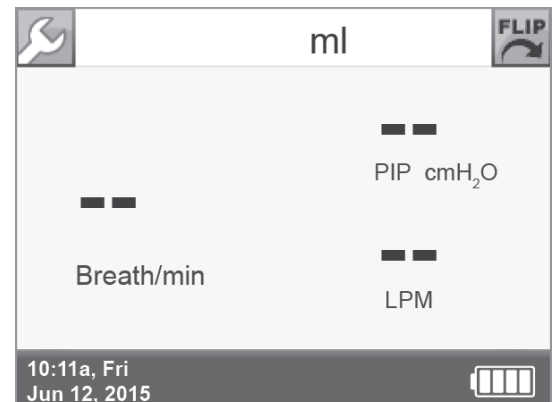

# Home Screen & Menu Overview cont'd.

## Home Screen

1. The **Wrench Button** is used to access the **Menu** screen
2. The current **Activity Icon** and **Output Volume** (displayed on the **Home Screen** during ventilation)
3. The **Flip Button** flips the screen 180°.
4. Peak Inspiratory Pressure (**PIP cmH<sub>2</sub>O**) indicator (displayed on the **Home Screen** during ventilation)
5. Current breath rate (**Breath/min or BPM**) (displayed on **Home Screen** during ventilation)
6. Average gas flow in liters per minute (**Air LPM** or **O<sub>2</sub> LPM**) based on prescription and patient's current breath rate (displayed on the **Home Screen** during ventilation).
7. **Battery Charge Icon**
8. Current **Activity Icon** (displayed during ventilation)
9. The **Vibration Icon** indicates that the ventilator is set for vibration.
10. Time and date

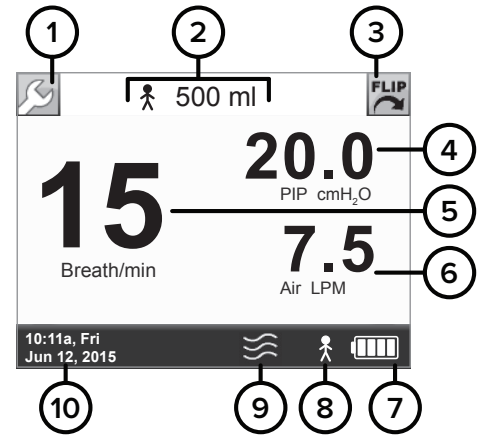

**NOTE:** The Home Screen will initially display LPM when the ventilator is first powered on. After an Activity Button is selected and ventilation begins, the Home Screen will display Air LPM or O<sub>2</sub> LPM based on the option prescribed and selected.

## Menu Screen

Use the Menu screen to access the Settings screen or Information screen (including software version and total operation time). To get to the Menu screen, touch the Wrench button from any screen.

1. **Screen title.**
2. Touch to go to the **Home Screen**
3. Touch to go to the **Settings Screen** for **Trigger Sensitivity**, **Clinician's Settings**, and **Utilities**.
4. Touch to go to the **Information Screen**.

**NOTE:** To toggle between the two screens, touch the Wrench button for the Menu Screen and the Home Screen button for the Home Screen.

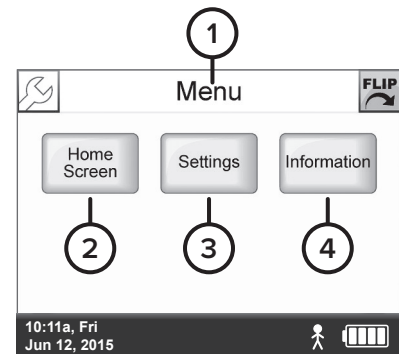



# Battery Information

If you intend to use the ventilator on battery power, make sure the battery is sufficiently charged for your duration of use. It takes approximately 3 to 4 hours to fully recharge the battery whether the ventilation is off or on. A fully charged battery should last up to four (4) hours.

1. Press the **Power button** to turn on the ventilator.
2. The green power indicator light shows that the ventilator is on.
3. Check the Ventilator **Battery Charge Icon** on the touch screen to see the current battery charge level for the ventilator. Refer to the chart below to determine the approximate amount of ventilator battery charge and the approximate time remaining.

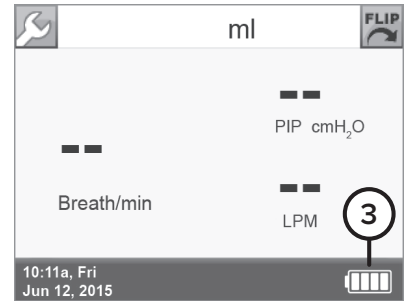
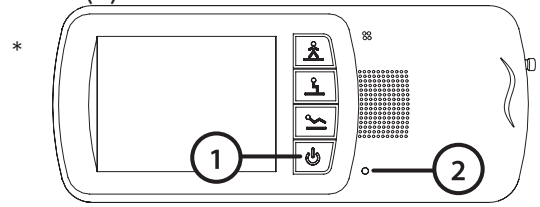

**NOTE:** The Ventilator Battery Charge Icon is always displayed on the touch screen during normal operation.

\*Ventilators may not be configured with the Battery Charger Dongle.

## Ventilator Battery Charge Icons for Ventilator REF MS-01-0100

BATTERY CHARGE ICON							
APPROX. CHARGE AMOUNT	Charging*	< 5%	< 15%	15–35%	36–56%	57–79%	80–100%
APPROX. TIME REMAINING	N/A	Critically low. Recharge immediately.	Less than 0.5 hour.† Recharge immediately.	0.5–1.5 hours‡	1.5–2.5 hours	2.5–3 hours	3–4 hours

## Ventilator Battery Charge Icons for Ventilator REF MS-01-0118

BATTERY CHARGE ICON							
APPROX. CHARGE AMOUNT	Charging*	< 5%	< 15%	15–35%	36–56%	57–84%	85–100%
APPROX. TIME REMAINING	N/A	Critically low. Recharge immediately.	Less than 0.5 hour.† Recharge immediately.	0.5–1.5 hours‡	1.5–2.5 hours	2.5–3 hours	3–4 hours

\* The charging icon may still appear when the ventilator is 100% charged.

† Very low battery alarm will sound with less than 15% charge.

‡ Low battery alarm will sound with less than 25% charge.

It may take up to 20 seconds, for the charging sign to appear/disappear after the charger is connected/disconnected from the ventilator.

# Cleaning & Maintenance

## Cleaning

### Life2000® Ventilation System

**Once a week (or more often if necessary):** clean and disinfect the ventilation system using a clean cloth, clean and disinfect the external surfaces of the ventilation system with 70% isopropyl alcohol or Clorox Disposable Wipes. Wipe the surface of the ventilation system with clean dry cloth to remove any residual cleaner.

**Daily (or more often if necessary):** check and empty the compressor's condensation tray and replace if necessary.

**Every three to six months (or more often if necessary):** check the compressor's air inlet filter and replace if necessary.

**Every three to six months (or more often if necessary):** check the compressor's cooling filter assembly and replace if necessary.

### CombO<sub>2</sub>® Hose

If dirt is visible on the outside of the hose, use a clean cloth and mild detergent such as dish-washing soap to remove it. **Replace every six months.**

#### **WARNING:**

Do not subject Breathe source gas supply hoses to heat sterilization, hot water pasteurization, autoclaving, radiation sterilization, ethylene oxide gas sterilization, or attempt to clean them in a dishwasher or microwave oven. Doing any of these may damage the hoses and impair gas delivery.

## Breathe Pillows Entrainment Interface

Breathe Technologies recommends a **90-day replacement** schedule for the Breathe Pillows Entrainment Interface. **Once a week (or more often if necessary):** Clean and purge the Breathe Pillows Entrainment Interface.

## Preventive Maintenance

Contact your service representative to make arrangements for preventive maintenance, service, and component replacement per the chart below. The ventilation system can only be serviced or repaired by an authorized service center.

REVISION	VENTILATOR	COMPRESSOR
Before Revision C	2.5 Years from ship date	1 Year from ship date
Revision C and after	2.5 Years from ship date	2.5 Years from ship date



## Environmental Specifications

Do not use the ventilation system if the ambient temperature is greater than 40°C (104°F) or less than 5°C (41°F). Store the ventilation system in ambient temperatures less than 60°C (140°F) and greater than -20°C (-4°F).

#### **WARNING:**

The rear housing of the ventilator enclosure may reach 49°C in a 40°C environment.

# Cleaning & Maintenance Cont'd.

## Cleaning the Breathe Pillows Entrainment Interface & Universal Circuit® Connector

1. Place the patient on an alternate means of ventilation, if necessary.
2. With the Interface fully disconnected from the ventilator, submerge the patient side of the Interface or the Universal Circuit® connector in a clean container of mixed warm water suitable for drinking and a mild detergent (e.g., dish-washing soap) and agitate the patient side of the interface to clean it.
3. Rinse the patient side of the interface thoroughly with warm water.

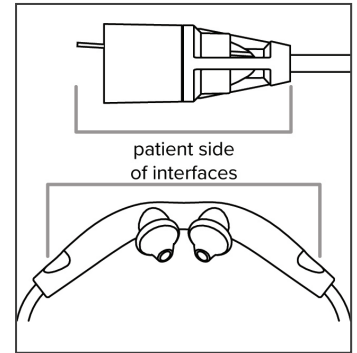

## Purging Interfaces using the Compressor

After cleaning and completely drying the interface or when you suspect dust or debris has entered the airflow passage, purge the interface with the purge tube connector and purge tube.

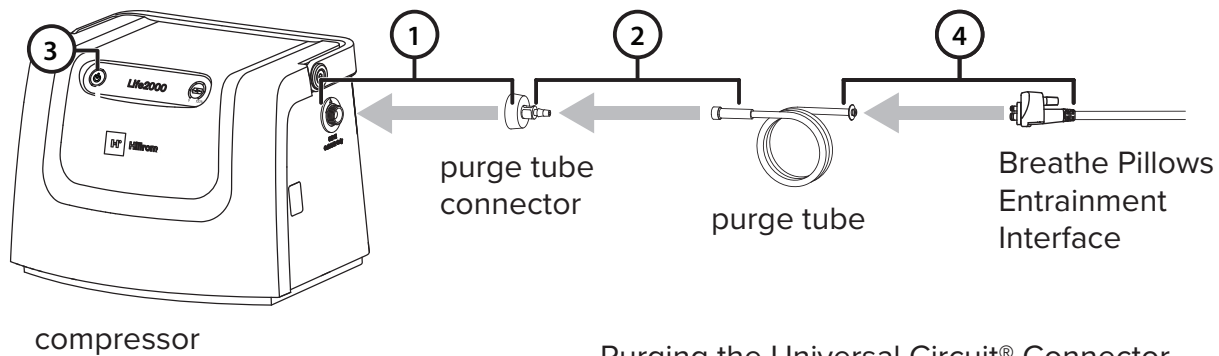

1. Connect the Purge Tube Connector to the gas inlet.
2. Connect the Purge Tube to the Purge Tube Connector.
3. Turn on the Compressor
4. Proceed to purge each port on the Interface

### Purging the Universal Circuit® Connector

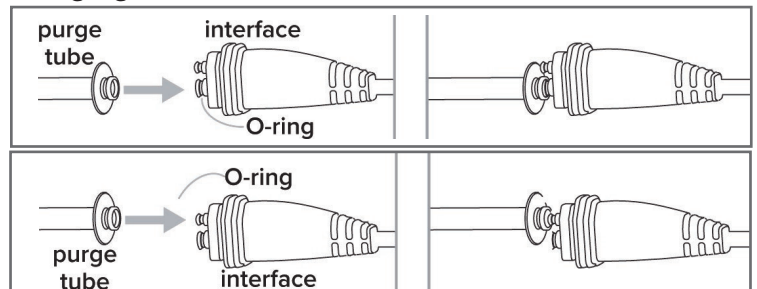

### Purging the Breathe Pillows Entrainment Interface

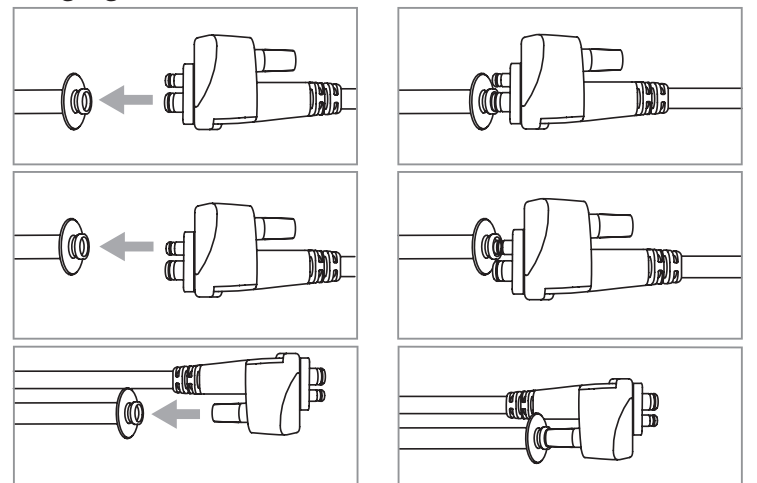

# Alarms and Troubleshooting

## Ventilator Alarms

When an alarm notification occurs, there is a distinct sound and a display message corresponding to the priority level of the alarm. The priority level of an alarm is indicated by the color and the rate at which the message flashes.



### High-Priority Alarm

A red, rapidly flashing alarm message is an alarm that indicates a situation that requires immediate attention.

Sound: Sequence of two sets of five tones.



### Medium-Priority Alarm

A yellow, steadily flashing alarm message is an alarm that indicates a potentially hazardous situation that must be resolved in a timely manner. Sound: Sequence of three tones.



### Low-Priority Alarm

A blue, non-flashing alarm message is an alarm that indicates a problem that is not hazardous but should be resolved.

Sound: Single tone.

Please see next page for assistance in solving ventilator alarms.

**NOTE:** When attempting to resolve alarm conditions, ensure that the patient receives adequate ventilation therapy; place the patient on an alternate means of ventilation if necessary.

## How to Silence and Clear On-Screen Alarms

Alarm notifications that appear on the touch screen originate from the ventilator. Silencing and cleaning on-screen alarms depends on alarm priority and number of active alarms.

Press the Silence Alarm button to temporarily silence the on-screen alarm for 60 seconds. Pressing the Silence Alarm button silences only one alarm at a time. If more than one on-screen alarm occurs, press the Silence Alarm button once for each alarm. If the on-screen alarm is a medium or high priority alarm and is not silenced after 60 seconds, the alarm will continue with an additional buzzer.

A visible message will be displayed for High Priority alarms (High Temperature, High Circuit Pressure, and High PEEP alarms) When the alarm is resolved, touch Ok in message box to clear the message.

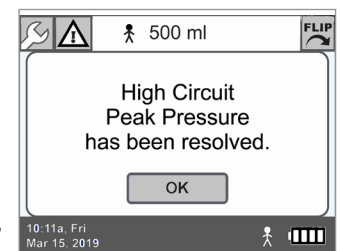
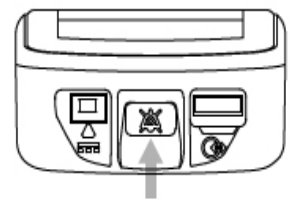

# Ventilator Alarms

Ventilator Alarms	What to do about it
High Circuit Pressure	Check the interface tubing for pinches and kinks. Replace the interface if alarm persists.
High PEEP Pressure	Interface may be blocked. Inspect and clean the interface per IFU.
High PIP Pressure	Check the interface and tubing and connectors for possible obstruction or damage.
High Temperature	Is the ventilator well aired & away from heat source? Call your provider if alarm persists.
Very Low Battery	Battery charge is below 15%. Recharge the battery. Call your provider if alarm persists.
Battery Low	Battery charge is below 25%. Recharge the battery. Call your provider if alarm persists.
Breath Timeout	Check if patient is breathing through the nose. Ensure interface is not leaking or clogged.
High Breath Rate	Check patient's breathing rate. Check for leakage or occlusion. Adjust trigger sensitivity.
High Delivery Pressure	Check the interface tubing for pinches and kinks. Replace the interface if alarm persists.
High Gas Pressure	Check gas source pressure. Discontinue ventilator use; call your provider if alarm persists.
Low Breath Rate	Check if patient is breathing through the nose. Ensure interface is not leaking or clogged.
Low Delivery Pressure	Check interface connection. Check interface tubing for possible leakage or damage.
Low Gas Pressure	Check gas supply and pressure. Check connections for leak. Check tubing for kinks.
Low PIP Pressure	Check for leakage. Switch activity button. Call your provider if alarm persists.
System Fault	Reboot the ventilator. If fault persists, use alternate ventilation & call your provider.
POST System Fault	Restart the ventilator. If fault persists, use alternate ventilation & call your provider.

# Compressor Alerts

The compressor has alerts that are independent of the ventilator. Compressor alerts must be resolved in order for the compressor alerts to be silenced; there is no Silence Alarm button for alerts originating from the compressor. See below for compressor alerts and their resolutions.

Troubleshooting - Compressor Alerts	
Low Battery Alert (Intermittent buzzer)	<p>Connect the compressor to an AC power source.</p> <p>If the battery does not recharge, place the patient on an alternate means of ventilation (if necessary) and contact your healthcare provider.</p>
Constant Audible Alert (Compressor stops operating)	<p>Discontinue use of the compressor. Place the patient on an alternate means of ventilation (if necessary), or connect the ventilator to an alternate pressure source (oxygen cylinder or wall source) in Stand Alone Configuration.</p> <p>If running on battery, check the compressor's battery charge status. If the status is less than two indicator lights, connect the compressor to an AC power source.</p> <p>Power off the compressor and power it on again. If the alert persists, power off the compressor and contact your healthcare provider.</p>

**NOTE:** When attempting to resolve alert conditions, ensure that the patient receives adequate ventilation therapy; place the patient on an alternate means of ventilation if necessary.

**NOTE:** For additional troubleshooting tips, refer to the IFU online or contact your provider.

Setup By (Company Name):

Company Phone Number:

Clinician Name:

Setup Date:

## Required for the Life2000 Ventilation System Patient Setup

- Life2000<sup>®</sup> Ventilator
- Life2000<sup>®</sup> Compressor
- Breathe Pillows Entrainment Interface
- Ventilator Battery Charger
- Compressor Battery Charger
- CombO<sub>2</sub><sup>®</sup> 50 ft. Hose
- 6 ft. Oxygen Hose
- Ventilator Carry Case
- Ventilator Belt Clip
- Purge Tube
- Purge Tube Connector
- Diss Regulator (\*not provided)
- Quick Reference

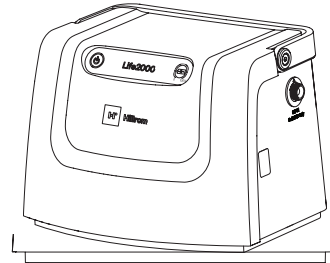

Life2000<sup>®</sup> Compressor

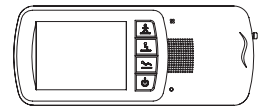

Life2000<sup>®</sup> Ventilator

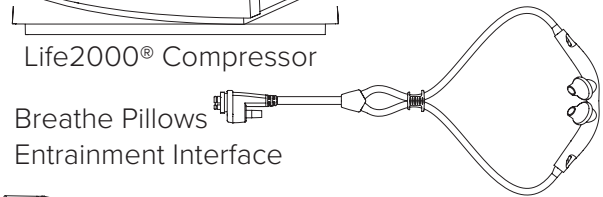

Breathe Pillows Entrainment Interface

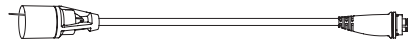

Universal Circuit<sup>®</sup> Connector

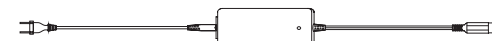

Ventilator Battery Charger

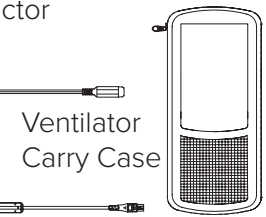

Ventilator Carry Case



Compressor Battery Charger

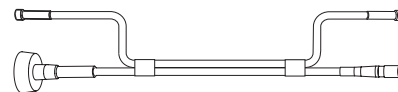

CombO<sub>2</sub><sup>®</sup> 50 ft. Hose



Ventilator Belt Clip

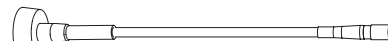

6 ft. Oxygen Hose

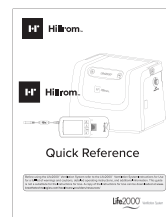

Quick Reference

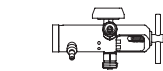

\*Diss Regulator

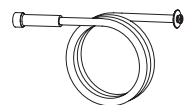

Purge Tube



Purge Tube Connector

# Life2000<sup>®</sup>



Featuring POV<sup>®</sup> Technology

Proportional Open Ventilation<sup>®</sup>

**Technical Support and Customer Service**

In the USA, call Hill-Rom at 800-426-4224.  
Outside of the USA, contact your distributor,  
local Hill-Rom representative, or go to  
[respiratorycare.hill-rom.com](https://respiratorycare.hill-rom.com).

Instructions for use are available for download at:

<https://www.hillrom.com/en/products/life2000-system/>

80029589, April 2023

©2023 Breathe Technologies, A Hillrom Company. Breathe, Breathe Pillows Interface, Breathe Technologies, Life2000, and Universal Circuit are trademarks of Breathe Technologies, a Hillrom Company. All Rights Reserved.