



Hillrom™

Envella® Air Fluidized Therapy System

Instructions for Use
(Rental Only)

Product No. P0819



Serial number V222EN and earlier labeled for US market only

194344 REV 6

REVISION

© 2021 by Hill-Rom Services, Inc. ALL RIGHTS RESERVED.

PATENTS / PATENT hillrom.com/patents

May be covered by one or more patents. See the above Internet address.

The Hill-Rom companies are the proprietors of European, US, and other patents and pending patent applications.

Manufactured by:

HILL-ROM, INC.
1069 STATE ROUTE 46 E
BATESVILLE, IN 47006-9167 USA

No part of this text shall be reproduced or transmitted in any form or by any means, electronic or mechanical, including photocopying, recording, or by any information or retrieval system without written permission from Hill-Rom Services, Inc. (Hill-Rom).

The information in this manual is confidential and may not be disclosed to third parties without the prior written consent of Hill-Rom.

The information in this manual is subject to change without notice. Hill-Rom makes no commitment to update or keep current the information in this manual.

Hill-Rom reserves the right to make changes without notice in design, specifications, and models. The only warranty Hill-Rom makes is the express written warranty extended on the sale or rental of its products.

This manual (194344) was originally released and supplied in English. For a list of available translations, contact Hill-Rom Technical Support.

Product images and labels are for illustrative purposes only. Actual product and label may vary.

Sixth Edition, 2021-12

First Printing, 2016

Clorox Healthcare® is a registered trademark of Clorox Professional Products Company.

Oxycide® is a registered trademark of EcoLab USA, Inc.

Oxivir® and Virex® are registered trademarks of DIVERSEY, Inc.

Wex-Cide™ is a trademark of Wexford Labs, Inc.

Hillrom™ and Quick View™ are trademarks of Hill-Rom Services, Inc.

Envella®, Graphical Caregiver Interface (GCI)®, and Point of Care® are registered trademarks of Hill-Rom Services, Inc.

Replace this manual (194344) if it is damaged and/or can not be read.

For product support or to order additional printed copies of this manual (194344), call 800-638-2546, contact your local Hill-Rom representative, or go to hillrom.com

NOTE:

A digital version of the user manual is available on the bed's GCI.

Reference Documents

Envella® Air Fluidized Therapy System Service Manual (194345)

NOTES:

Table of Contents

Revision.....	i
Intended Use.....	1
Introduction.....	1
Air Fluidized Therapy.....	1
Pressure Redistribution Therapy.....	2
Graphical Caregiver Interface (GCI) [®] Control.....	2
Symbols.....	2
Document Symbols.....	2
Product Symbols.....	3
Caregiver Control Panel.....	3
Pendant (Hand) Controls.....	3
Graphical Caregiver Interface (GCI) [®]	4
Other GCI Symbols.....	4
Bed Frame Labels.....	5
Safety Information.....	6
California Proposition 65 Statement.....	8
Quick View [™] List of Features and Controls.....	9
Alarm Conditions.....	10
Notification Priority.....	10
Bed Temperature Too High / Communication Issue.....	10
Power Loss.....	11
Alerts and Information Indicators.....	11
Audible Alerts and Indicators.....	11
Brake Not Set.....	12
Visual Alerts and Indicators on the Caregiver Control Panels.....	12
Visual Indicator on the Upper Frame.....	12
Bed Frame Features.....	13
CPR Control.....	13
Use the CPR Control.....	13
Power Cord.....	14
Cord Hooks.....	14
Brake and Steer Controls.....	14

Siderails.....	15
Remove a Siderail	15
Install a Siderail.....	16
Patient Restraint and Drainage Bag Holders	16
Patient Restraints.....	16
Drainage Bag Holders	16
Equipment Rail.....	17
Equipment Sockets.....	17
Night Light.....	18
Line Manager	18
Support Surface	18
Air Fluidization Therapy Beads (A).....	19
Filter Sheet (B).....	19
Pressure Redistribution Therapy Cushions (C).....	20
Clean Environment.....	20
Point of Care® Bed Controls	21
Lockout.....	21
Head Up and Down.....	22
Bed Up and Down	22
Bed Therapy (Air Fluidization).....	23
Turn Bed Therapy On and Off.....	23
Surface Transfer	24
Transfer a Patient On to the Bed from a Bed, Stretcher, or other Flat Surface.....	24
Transfer a Patient Out of the Bed to another Bed, Stretcher, or other Flat Surface	25
Side Transfer	25
Transfer a Patient On to the Bed from a Standing or Chair Position	26
Transfer a Patient Out of the Bed to a Side-Sitting Position for Standing or Placement into a Chair.....	26
Foot Control for Bed Therapy (Air Fluidization)	27
Pendant (Hand Control)	27
Adjust the Head Elevation	27
To Adjust the Comfort Settings for the Low Back, Upper Back, and Head Comfort.....	27
Graphical Caregiver Interface (GCI)® Controls	28
Unlock the GCI	28
Lock the GCI.....	28

Use the GCI Menu Controls	29
Access the Help (?) Menu	30
Alerts	30
Bed Exit Alert.....	30
Turn the Bed Exit Alert On	31
Turn the Bed Exit Alert Off.....	32
Silence the Bed Exit Alert without Deactivating the System	33
View Bed Exit Alert History.....	35
Bed Exit Alert System Messages.....	35
Head Angle Alert	37
Activate the Head Angle Alert	37
When the Head Angle Alert Sounds.....	38
Turn Off the Head Angle Alert	38
View the Head Angle Alert History	39
Head Angle Alert Messages.....	40
Change the Alert Volume.....	40
Change the Alert Tone.....	41
Scale.....	41
Scale Specifications	41
Weigh the Patient	41
View Weight History.....	43
Weigh Patient Messages.....	44
Zero the Scale.....	45
Zero Scale Messages	47
Body Mass Index (BMI) Calculator	47
Adjust Weight.....	48
Add/Remove Items.....	49
Bed Therapy	52
Adjust the Comfort Level	52
Adjust the Temperature	53
View Bed Therapy History	54
Bed Therapy—Air Fluidization and Temperature Messages	55
Bed Therapy System Messages.....	56
Miscellaneous Messages.....	57
Turn Reminder	58

Preferences	59
History	59
Adjust Date/Time	60
Electrocardiogram and Electroencephalogram	61
Position the Patient	61
Adjust the Patient's Position	61
Turn the Patient for Side Lying with a Pillow	61
Turn the Patient for Linen Changes	62
Turn the Patient for Back, Wound, and Perineal Care	63
Adjust the Female Patient's Position for Catheterization	64
Adjust the Patient's Position for Bedpan Use	65
Transport	66
Transport the Bed	67
After Transport	67
Accessories	68
Patient Helper (P0820)	68
Foot Support Cushion (195108)	70
Impervious Sheet (P007012A)	70
Infusion Support System (P158A)	71
IV Pole (P2217A)	71
Oxygen Tank Holder, Vertical (P276 and P27601)	72
Detachable parts	73
Cleaning and Disinfecting	73
Recommendations	74
Cleaning and Disinfection	74
Prepare the Bed for Cleaning and Disinfecting	75
STEP 1: Cleaning	75
STEP 2: Disinfection	76
Process the Bed after Patient Use	76
Maintenance	77
Service Calls	77
Troubleshooting	77
Storage and Handling	77
Specifications	78

INTENDED USE

The Envella® Air Fluidized Therapy System is intended for medical purposes to help treat or prevent pressure injuries, to treat severe or extensive burns, or to aid in circulation. This bed is an ideal support for patients who have advanced pressure injuries, flaps, grafts, or burns, and require frequent transfers or variable head elevation, and any other conditions appropriate for air fluidized therapy. The bed also can be used for intractable pain, extensive epidermal detachment, Stevens-Johnson Syndrome, purpura fulminans, induce relaxation which may reduce need for sedative and pain medication, improve patient outcome, and reduce wound healing time. The bed permits easy positioning and egress, thereby enhancing the independence of patients.

INTRODUCTION

The Envella® Air Fluidized Therapy System is a patient management system that combines air fluidized therapy and pressure redistribution technologies together on a low-height frame. The lower body section provides air fluidized therapy, and the upper body section provides pressure redistribution.

The bed is most applicable in the long term care and acute care, medical, surgical, and critical care settings, but it may be used in other clinical areas as well.

The bed supports these types of patients:

- Patients in need of aggressive treatment for multiple or advanced pressure injuries
- Patients receiving treatment for flaps, grafts, burns, or intractable pain
- Patients at high risk for skin breakdown (to prevent pressure injuries)



The bed may be used when continuous or variable head elevation and/or patient transfers and egress may be required.

The bed is equipped with a scale intended to weigh the patient in the bed.

Before you operate the bed, make sure you read and understand in detail the contents of this manual. It is important that you read and obey the aspects of safety contained in this manual.

Any reference to a side of the bed is from the patient's view lying in the bed on his or her back.

AIR FLUIDIZED THERAPY

To support the patient's buttocks, legs, and feet, the lower-body portion of the bed provides the maximum pressure relief of air fluidized therapy. The bed's air fluidization chamber contains silicone coated microspheres (beads).

When the bed is turned on, room air is drawn into the base of the bed, filtered, heated, and channeled into the bed through a porous diffuser. The air blows upward through the beads, and puts them into motion, causing the beads to take on the properties of a fluid that the patient's body can float in.

If the airflow is turned off, the beads settle into a mold around the body contours, creating a solid support.

PRESSURE REDISTRIBUTION THERAPY

To support the patient's head, shoulders, and back, the upper-body portion of the bed delivers pressure redistribution therapy by controlling the escape of air and pressure distribution in the inflatable cushions. The air is automatically adjusted for the patient's weight, as well as changes in the patient's position and head elevation. The patient receives support according to the individual's comfort at therapeutic pressures.

GRAPHICAL CAREGIVER INTERFACE (GCI)[®] CONTROL

The GCI at the foot end of the bed constantly provides information about bed features and the bed status. Menus guide you through the bed functions. To access the features, press the controls on the GCI. Indicator lights show when a feature is on.



Some bed controls are available on the pendant (hand control), footboard, and sides of the bed.

SYMBOLS

DOCUMENT SYMBOLS

This manual contains different typefaces and symbols to make the content easier to read and understand:

- Standard text—used for regular data.
- **Boldface text**—emphasizes a word or phrase.
- **NOTE:**—sets apart special data or important instruction clarification.
- WARNING, CONTRAINDICATION, or CAUTION



- A CONTRAINDICATION identifies situations or actions that may have an effect on patient safety.
- A WARNING identifies situations or actions that may have an effect on patient or user safety. To ignore a warning could cause patient or user injury.
- A CAUTION identifies special procedures or precautions that persons must obey to help prevent equipment damage.

PRODUCT SYMBOLS

Caregiver Control Panel

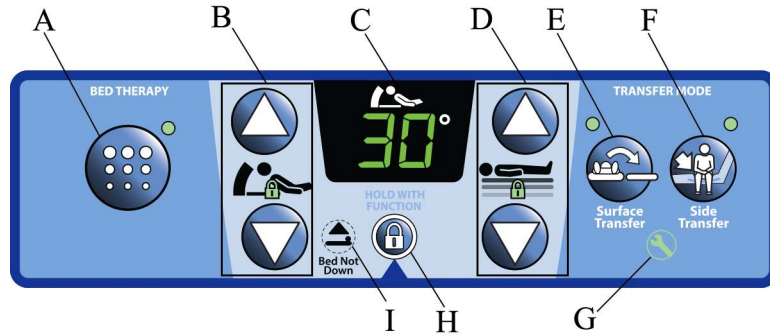

Item or Symbol	Description	Item or Symbol	Description
A	Bed therapy (air fluidization) control with indicator	F	Side transfer control with indicator
B	Head up and down controls with lockout indicator	G	Service required indicator
C	Head angle display (on the head-end side controls only)	H	Lockout control
D	Bed up and down controls with lockout indicator	I	Bed not down indicator
E	Surface transfer control with indicator		Bed Unplugged Alarm indicator (on the footboard controls only)

Pendant (Hand) Controls

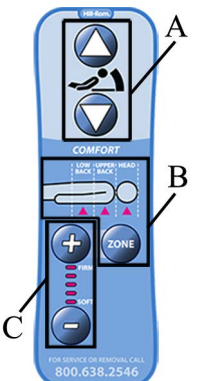
	Item	Description
	A	Head up and down controls
	B	Comfort adjust zone select control with indicators
	C	Comfort adjust pressure increase and decrease controls with indicators

Graphical Caregiver Interface (GCI)®

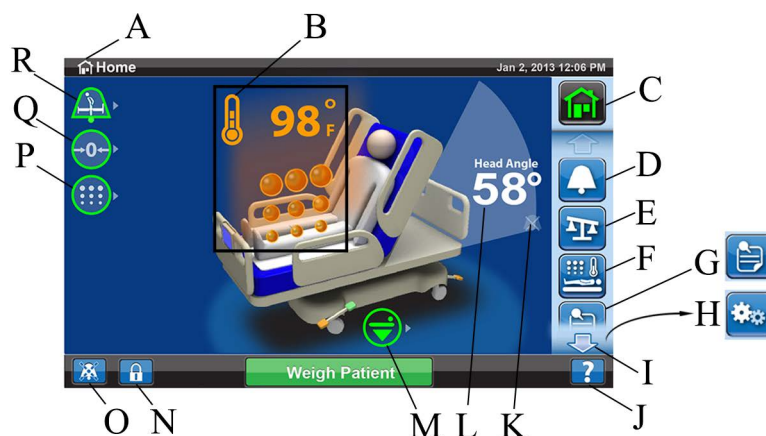

















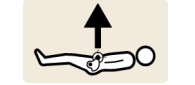









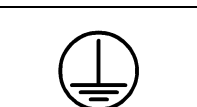



Item	Description	Item	Description
A	Home screen indicator	J	Help (?) control
B	Temperature Status indicators— <ul style="list-style-type: none"> • Green = the surface is at its setpoint • Orange = the surface is heating • Blue = the surface is cooling 	K	Head Angle Alert Status indicator
C	Home Menu control	L	Head Angle display
D	Alerts Menu control	M	Bed Height Status indicator
E	Scale Menu control	N	Screen Lock control
F	Bed Therapy Menu control	O	Preemptive Bed Exit Alert Silence control
G	Reminder Menu control	P	Air Fluidization Status indicator
H	Preferences Menu control	Q	Scale Zero Status indicator
I	Down (and up) arrow control	R	Bed Exit Alert Status indicator

Other GCI Symbols

Symbol	Description	Symbol	Description
	Alert Volume control		Patient Height Input control
	Alert Tone control		Increase and Decrease controls
	Temperature Adjust controls		Return control
	Temperature Unit control		Identifies that the alarm system is in the audio off state.
	Identifies an alarm condition		

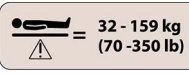
Bed Frame Labels

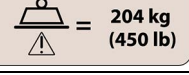
Symbol	Description	Symbol	Description
	CPR control label		WARNING (yellow and black)
	Patient left head rail (on the siderail)		CAUTION (white and black)
	Patient right head rail		Identifies patient chest restraint location
	Patient left foot rail		Identifies patient waist/wrist restraint location
	Patient right foot rail		Identifies patient ankle restraint and/or drainage bag location
	Siderail release controls		Brake pedal
	Hip position locator		Steer pedal
	Safe working load for the footboard rail		Before transport sequence
	Detachable intermediate siderail—left		After transport sequence
	Detachable intermediate siderail—right		Crush warning: must consult accompanying documents
	Detachable head siderail—left		Identifies the bed power cord
	Detachable head siderail—right		Refer to the service manual for fuse replacement and identification
	IV pole interference		Protective earth
	Do not use with Oxygen Tents		ATTENTION: Consult accompanying documents

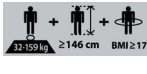
Symbol	Description	Symbol	Description
	Warning: no equipment storage		Must consult accompanying documents
	Type B applied part according to IEC 60601-1	IPX4	According to IEC 60529, Rating for protection against fluid ingress and identified as equipment that is protected against spraying and splashing water
	Medical Equipment with respect to Electric Shock, Fire and Mechanical Hazards only in accordance with ANSI/AAMI ES60601-1, IEC60601-1, IEC60601-2-52, and IEC80601-2-35, and CAN/CSA C22.2 No. 60601-1		Manufacturer
	Patient minimum and maximum weight range		Manufacture date
	Patient minimum and maximum weight range	REF	Catalog number
	Safe working load	SN	Serial number
	Total bed weight (including the safe working load)		Medical Bed for Adults

SAFETY INFORMATION



CONTRAINDICATION:

Use of active therapy surfaces with patients with unstabilized spinal cord injury could cause serious injury to the patient.

**WARNING:**

Obey all **warnings** throughout the manual and also the warnings below. Failure to do so could cause injury and/or equipment damage:

- **Warning**—Read and understand all warnings in this manual and on the bed itself prior to use with a patient.
- **Warning**—Follow the product manufacturer’s instructions.
- **Warning**—Contact Hill-Rom if any of these occur:
 - The product does not respond to user controls as described in this manual.
 - “Notify Hill-Rom” shows on the GCI and an alert sounds.
 - There is an electrical or mechanical problem with the bed.
 - Air fluidization is sluggish or uneven, and **not** caused by blankets and pillows on the bed or recent fluid ingress into the beads.
- **Warning**—To help prevent the risk of hospital bed fires, make sure facility persons follow the safety tips in the *FDA Public Health Notification: Safety Tips for Preventing Hospital Bed Fires*. (US only)
- **Warning**—The potential for electrical shock exists with electrical equipment. Failure to follow facility protocols may cause death or serious injury.
- **Warning**—Connect the power cord to a hospital grade power outlet only. (To avoid risk of electric shock, this equipment must only be connected to a supply mains with protective earth.)
- **Warning**—Do not connect the power cord to an extension cord or multiple outlet strip. There is a risk of overheating and fire may cause injury or damage.
- **Warning**—Incorrect use or handling of the power cord may cause damage to the power cord which could cause electrical shock or other injury. If damage has occurred to the power cord or any of its components, immediately remove the bed from service, and contact Hill-Rom.
- **Warning**—Make sure the location of the power cord from the bed to its power source is such that the cord will not cause a trip hazard.
- **Warning**—The bed is intended for patients who are within the specified weight limit of 32 kg to 159 kg (70 lb to 350 lb). Use of the bed with a patient whose weight is outside of the specified limits may cause loss of therapeutic value and/or damage to the bed.
- **Warning**—This bed is not designed for use with oxygen tents and their accessories. Use oxygen administering equipment of the nasal, mask, or ventilator type only.
- **Warning**—To prevent a risk of explosion, do not use oxygen administering equipment in the presence of flammable anesthetics.
- **Warning**—Use detachable parts and accessories from Hill-Rom only. Do not modify or change the bed system without approval from Hill-Rom.
- **Warning**—Rental only product—there are no user replaceable service parts. For service part replacement, contact Hill-Rom.
- **Warning**—Make sure that there are no foreign objects in the patient zone of the bed.
- **Warning**—A patient with continuous exposure to warm, dry air is subject to increased evaporative water loss. Monitor the patient’s fluid status, and provide hydration therapy as needed.
- **Warning**—This product contains chemicals known to the State of California to cause cancer and birth defects or other reproductive harm.
- **Warning**—Make sure that the patient is in the correct position on the bed. Patient injury can occur.



CAUTION:

Caution—Do not store anything under the bed. To do so could cause equipment damage.

NOTES:

- To remove power from the bed, unplug its power cord from the AC power outlet.
- To make sure grounding is reliable, fully insert the plug into the power source.
- Make sure the position of the bed is such that you can quickly, without obstruction, unplug the power cord from the main power supply if necessary.
- Rental only product—do not dispose of any parts of the bed. Contact Hill-Rom.

CALIFORNIA PROPOSITION 65 STATEMENT



WARNING:

Warning—This product can expose you to chemicals including Lead and Di (2-ethylhexyl) phthalate (DEHP), which are known to the State of California to cause cancer and birth defects or other reproductive harm. For more information go to www.P65Warnings.ca.gov.

QUICK VIEW™ LIST OF FEATURES AND CONTROLS

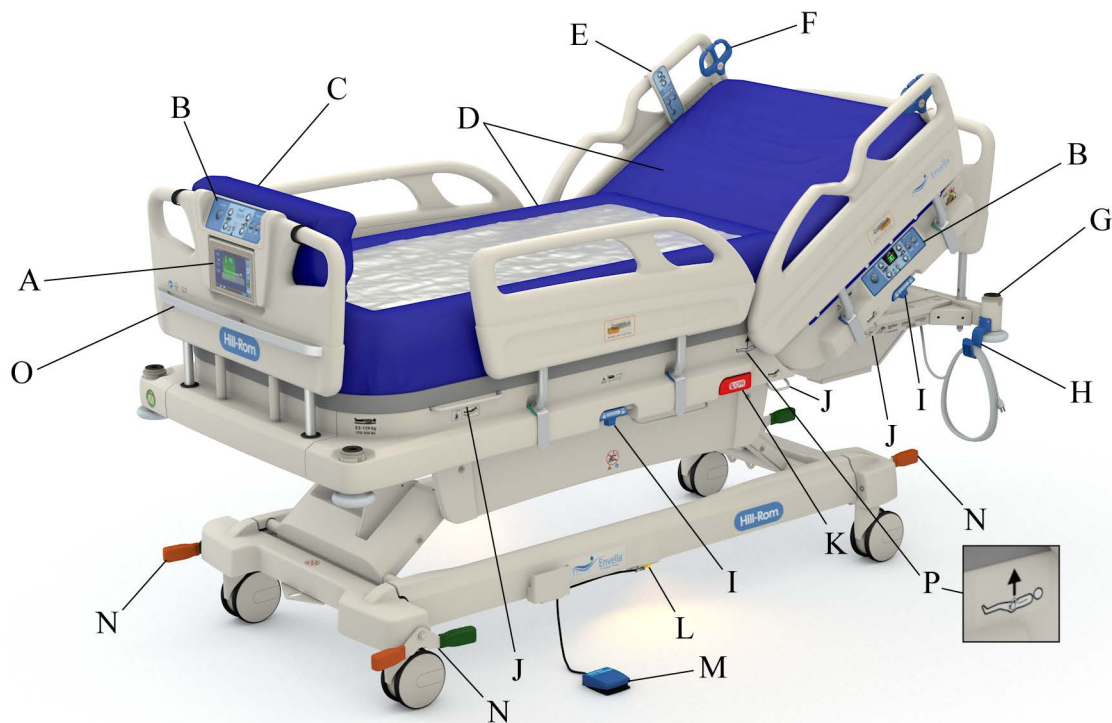

Item	Feature	Page	Item	Feature	Page
A	Graphical Caregiver Interface (GCI)®	28	I	Siderail release	15
B	Caregiver control panel	21	J	Patient restraint (the ankle restraints can also be used as a drainage bag holders)	16
C	Foot support cushion	21	K	CPR control	13
D	Support surface	18	L	Night light	18
E	Pendant	27	M	Foot control and holder	27
F	Line manager	18	N	Brake and steer control	14
G	Equipment socket	17	O	Equipment rail	17
H	Power cord hook	14	P	Hip position locator	61

ALARM CONDITIONS

Different alarms are generated by the bed to notify the caregiver of potentially hazardous conditions. The intended position of the caregiver to respond to alarms is standing in front of the GCI or control panel that is on the footboard of the bed.

There are two alarm conditions: **Bed Temperature Too High / Communication Issue** is a medium priority alarm, and **Power Loss** is a low priority alarm.

NOTIFICATION PRIORITY

Only one alarm or alert will show on the display at one time. Alarms are prioritized over alerts.

Priority	Indication	Condition	Visual Warning	Auditory Warning	Resolution
Medium (1 second inherent alarm delay)	Bed Temperature Too High / Communication Issue	The temperature in the bead section of the bed exceeds 104°F (40°C). Or There is a connection issue with the temperature sensor.	Warning on the GCI; the screen has a yellow border that flashes.	Triple beep that sounds repeatedly.	Follow the on-screen instructions.
Low	Power Loss	The bed power cord is disconnected from the AC power outlet. Or A power outage has occurred.	The Bed Unplugged Alarm indicator is on and is yellow colored.	None	Check that the power cord is plugged in. Wait for power return.

BED TEMPERATURE TOO HIGH / COMMUNICATION ISSUE

NOTE:

When you plug the bed into the power outlet, make sure that you hear a single beep. This lets you know that the **Bed Temperature Too High / Communication Issue** alarm is operating correctly.

A triple beep will sound repeatedly and Bed Therapy will be disabled if either of these conditions occur:

- The temperature in the bead section of the bed exceeds 104°F (40°C).
- There is a connection issue with the temperature sensor.

If the alarm sounds, remove the patient from the bed, and contact Hill-Rom.



To turn off the alarm sound, press the **Bed Therapy** control on one of the caregiver control panels. To turn the sound on again, press the **Bed Therapy** control.



POWER LOSS



WARNING:

Warning—A patient should **not** remain on the bed with air fluidization not operating for more than two hours.

A power loss can occur under these conditions:

- The bed power cord has been disconnected from the AC power outlet.
- A power outage has occurred.
- A bed fuse has blown.

During a power loss condition, the bed can not operate. If the bed has been without power for more than 2 hours (air fluidization has not operated), remove the patient from the bed.

When power is restored, the bed will resume operation at its previous state: if air fluidization was on, it will turn on; if air fluidization was off, it will remain off.

NOTES:

- To make sure the Power Loss Alarm indicator operates correctly, do as follows:
 1. Unplug the bed, and make sure that the indicator comes on.
 2. Plug the bed in, and make sure that the indicator turns off.
- The bed must be plugged into AC power to operate.
- The Power Loss Alarm indicator stays on for approximately 10 minutes after the bed has stopped receiving AC power.



ALERTS AND INFORMATION INDICATORS

Alerts and Information Indicators provide the caregiver with audible indicators and visual indicators. For detailed information about the **Bed Exit System** and **Head Angle** alerts, see “Alerts” on page 30.

NOTE:

There must be AC power to the bed for the indicators to operate.

AUDIBLE ALERTS AND INDICATORS

A single beep will sound when an activity is successful or completed.

A triple beep will sound when there is an error or caregiver attention is needed.

A triple beep will sound every 10 minutes when there is a bed malfunction.

A triple beep will sound every 5 seconds during these situations:

- When air fluidization is off because of a fan malfunction.
- When a patient is in the bed and air fluidization has been turned off for more than 30 minutes. The alert can be silenced and will sound again in 15 minutes if air fluidization is still off.

Brake Not Set

The Brake Not Set is an audible alert only. When the bed is plugged into AC power, and you release the brakes, the alert will sound. To silence the alert, either unplug the bed (for transport) or set the brakes.

VISUAL ALERTS AND INDICATORS ON THE CAREGIVER CONTROL PANELS

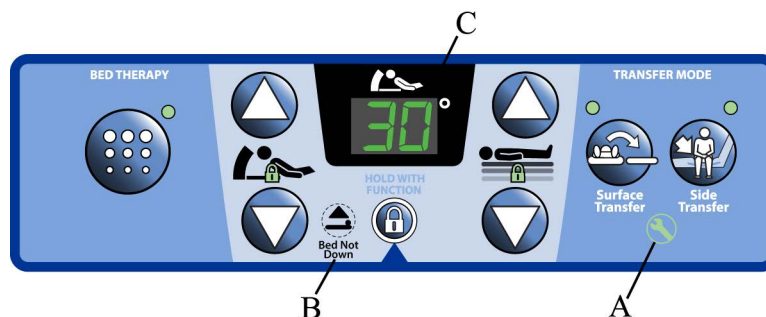

Item	Indicator
A	Service Required—flashes when the bed detects a malfunction. Contact Hill-Rom for assistance.
B	Bed Not Down—flashes when the bed is not in its lowest position.
C	Head Angle Display and Alert (side control panels only)—the display digitally shows the approximate angle of the head section from 0° to +60° with respect to the floor. The Head Angle Alert indicator is on when the Head Angle Alert is armed. The Head Angle display has an accuracy of $\pm 4^\circ$. (The head angle and its alert status also show on the GCI.)

VISUAL INDICATOR ON THE UPPER FRAME

A Hip Position Locator label is on both sides of the upper frame in between the attachment points for the head and intermediate siderails. The label identifies the correct location of the patient's hips while on the bed.



BED FRAME FEATURES

CPR CONTROL

A red CPR release handle is on both sides of the upper frame in between the attachment points for the head and intermediate siderails.



USE THE CPR CONTROL

1. **Pull and hold** the CPR control until you hear a single confirmation beep to let you know that bed has reached the CPR position, and then release the control:
 - If the bed **is plugged into AC power**, these will occur:
 - The head section lowers to the flat position.
 - Air fluidization turns off.
 - The cushions deflate within 2 minutes.
 - If the bed **is not plugged into AC power**, the bed will lower the head section to the flat position only. The cushions under the patient's back will not deflate.

NOTES:

- As soon as you pull the CPR control, the cushions under the patient's back will start to deflate. If you release the control before the bed has reached the full CPR mode, the cushions will continue to deflate.
 - If the bed **is plugged into AC power**, and you release the CPR control before you hear the single confirmation beep, the head section may not have reached the flat position, air fluidization will not turn off.
 - If the head section does not reach the flat position (0°) and Bed Therapy does not turn off, use the Bed Therapy On/Off control to turn off the therapy.
2. Put a CPR board under the patient.
 3. To deactivate the CPR mode, press one of these Point of Care® bed controls: **Bed Therapy**, **Surface Transfer**, or **Side Transfer**.

NOTES:

- Activation of the CPR mode affects these bed alerts and functions:
 - If the Bed Exit and/or Head Angle alerts are armed prior to the CPR transition, they will be canceled.
 - Controls that were locked out will be unlocked.
- If the bed is in CPR mode for more than 60 minutes, these occur:
 - An audible alert sounds.
 - An alert message shows on the GCI.

POWER CORD

The power cord at the head end of the bed supplies power to the bed.



NOTE:

When the bed is unplugged from its power source, the Power Loss Alarm indicator turns on and stays on for approximately 10 minutes.



Cord Hooks

There are two blue hooks on the inside of the head-end frame to stow the power cord for transport.



BRAKE AND STEER CONTROLS



WARNING:

Warning—Unless you are to transport the patient, always set the brakes when the bed is occupied. Make sure the brakes are set before any patient transfer on to or off the bed. Failure to do so may cause injury or equipment damage.

The Point-of-Care® brake and steer controls are above both foot-end casters and at the head-end of the bed. There are labels to identify the Brake and Steer mechanisms at the head-end of the bed. There are three positions:

- **Brake**—to prevent the bed from moving, step down on the **orange** brake pedal until it is in the full downward position.
- **Steer**—to move the bed in a straight line and guide it through hallways, step down on the **green** steer pedal until it is in the full downward position.
- **Neutral**—to move the bed in any direction, move the pedal to the **level** position. The neutral position helps with sideway movements in a room or a small enclosed area, or to align the bed with another surface.

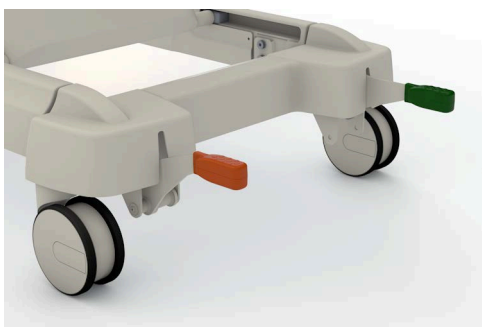

Head-End Pedals

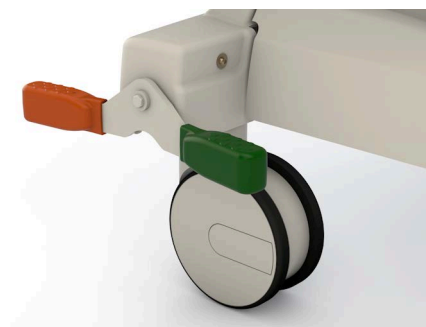

Foot-End Pedals

When the bed is connected to AC power, and you release the brake, the Brake Not Set alert sounds to let you know that the bed's brake is not set. To silence the alert, either unplug the bed (for transport) or set the brake.

SIDERAILS

The bed has detachable head and intermediate siderails for both sides of the bed. The siderails are designed to stand upright when they are not installed on the bed.



WARNING:

To help prevent injury and/or equipment damage, obey these **warnings**:

- **Warning**—Evaluate patients for entrapment risk in accordance with facility protocol, and monitor patients appropriately. Make sure all siderails are fully inserted and locked when installed. Failure to do either of these could cause serious injury or death.
- **Warning**—Before you remove or install a siderail, make sure that persons, objects, medical lines, and devices are away from the bed's moving mechanisms.
- **Warning**—Before you remove or install the siderails, make sure the patient's extremities are in a position so that the patient does not get injured.
- **Warning**—When you remove a siderail, do not lay it flat on the floor. Store the siderail in an upright position or location so that it does not come in contact with biohazards or cause a trip hazard.
- **Warning**—To reduce the risk of patient entrapment and falls, use only the siderails that Hill-Rom provides with the bed.

NOTES:

- Siderails are intended to be a reminder to the patient of the bed's edges, not a patient-restraining device. When applicable, Hill-Rom recommends that medical persons determine the correct methods necessary to make sure a patient remains safely in bed.
- When Bed Exit is armed and you remove or install a siderail, the Bed Exit alert sounds.

Remove a Siderail

1. Slide the siderail release lever to the **Unlocked** position, and hold the lever there as you lift up and remove the siderail. When you release the lever, it will return to the locked position.

NOTES:

- To help make the intermediate siderail easier to remove, do these:
 - Gently push the siderail in towards the bed as you slide the release lever.
 - Hold the siderail at the center of the top of the rail, and lift the rail straight up to remove it.
- If you can not slide the release lever, press down on the siderail to make sure that it is locked in position. Then, slide the release lever.



2. Stand the siderail upright in a safe location.



Install a Siderail

1. Set the siderail securely into the color-coded siderail receptacles, and push down on the siderail. You will hear a beep when the siderail has locked in position.
2. Pull on the siderail to make sure it is correctly locked in position.

NOTE:

If you do not install a siderail correctly, the Home screen on the GCI will flash the siderail that is not installed correctly.

PATIENT RESTRAINT AND DRAINAGE BAG HOLDERS

Patient Restraints

The bed facilitates the use of ankle, waist/wrist, and chest restraints.

Hill-Rom makes no recommendation in regard to the use of physical restraints. Refer to legal restrictions and appropriate facility protocols before you use physical restraints.

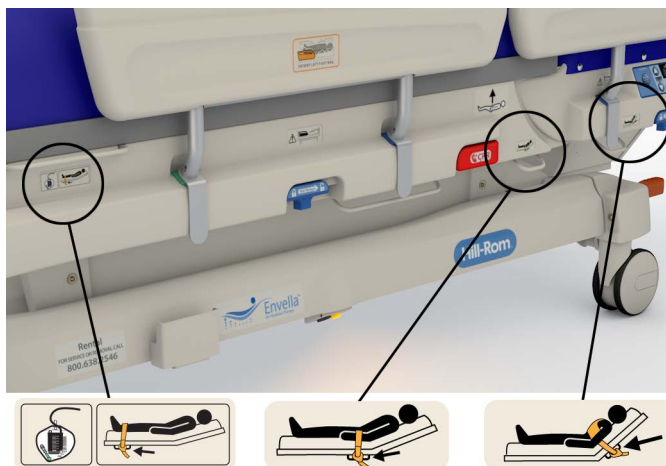

WARNING:

Warning—Restraints must be attached to the articulating sections of the bed at the correct attachment points. Otherwise, patient injury could occur.

Drainage Bag Holders

The ankle restraint holders at the foot end of the bed can be used as drainage bag holders.



In addition to the ankle restraint holders at the foot end of the bed, you can also hang drainage bags on the holders that are on each side of the bed between the CPR release and intermediate siderail release, and on the footboard equipment rail (see “Equipment Rail” on page 17).

The holders accommodate any combination of the following drainage devices:

- Fecal incontinence bag
- 250/2000 ml Foley collection bag
- Chest drainage device on foot-end holders

Make sure drainage bags and hoses are placed so they will not touch the floor during bed articulations.



WARNING:

Warning—Use caution when you put the drainage bag tubing in position. Keep it away from moving parts. Otherwise, injury or equipment damage could occur.



CAUTION:

To help prevent equipment damage, obey these **cautions**:

- **Caution**—Do not exceed the 10 lb (4.5 kg) load capacity (safe working load) of each drainage bag holder.
- **Caution**—During transport, do not hang drainage bags on the siderails.

NOTE:

The weight of the drainage bags on the bed affects the scale reading.

EQUIPMENT RAIL

An equipment rail is on the footboard, beneath the GCI.



CAUTION:

Caution—Do not exceed the 30 lb (13.6 kg) load capacity (safe working load) of the equipment rail. To do so could cause equipment damage.



EQUIPMENT SOCKETS

There are four equipment sockets for the attachment of accessories. They are at each corner of the bed.

The equipment sockets can be used to mount IV poles and oxygen tank holders.



NIGHT LIGHT

A night light is on each side of the base frame, near the hip section.

The lights are on continuously when the bed is plugged into AC power.



LINE MANAGER

The line managers help keep lines such as IVs, suction tubing, and monitor cables together and away from the articulation of the frame.



WARNING:

To help prevent injury and/or equipment damage, obey these **warnings**:

- **Warning**—Do **not** use the line managers to secure ventilator tubing; use only approved ventilator tubing devices.
- **Warning**—Do **not** wrap power cords around the line managers.

SUPPORT SURFACE

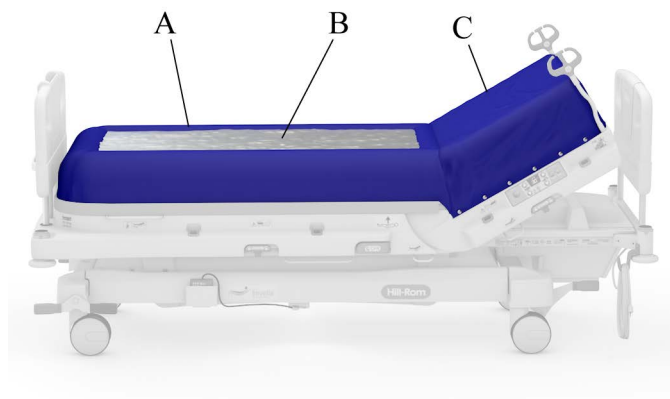

The Support Surface consists of these:

- Air Fluidization Therapy Beads (A) that support the patient's hips/buttocks, legs, and feet.
- Filter Sheet (B) that separates the air fluidization beads from the patient.
- Pressure Redistribution Therapy Cushions (C) that support the patient's head, back, and lumbar areas.

AIR FLUIDIZATION THERAPY BEADS (A)

Air Fluidization therapy supports the patient's hips/buttocks, legs, and feet. This area of the bed provides maximum pressure redistribution and reduction in shear, friction, and moisture. The bed's air fluidization chamber contains tiny silicone coated microspheres (beads). When the bed is turned on, room air is drawn into the base of the bed, filtered, heated, and channeled into the bed through a porous diffuser. The air blows upward through the beads, and puts them into motion. This causes the beads to take on the properties of a fluid that the patient's body can float in. If the airflow is turned off, the beads settle into a mold around the body contours and create a solid support.

NOTE:

You can adjust the bead section for comfort based on patient needs through the Bed Therapy Menu on the GCI (see page 52).

The beads are tiny silicone coated microspheres. The beads are non-toxic, and do **not** contain any free silica. There is **no known** risk for silicosis.

The beads are biocompatible. However, some people have shown a skin sensitivity to them.



WARNING:

To help prevent injury and/or equipment damage, obey these **warnings**:

- **Warning**—After contact with beads, always wash your hands, and do not rub your eyes. If beads contact the eyes, corneal abrasions or inflammation could occur.
- **Warning**—The beads are slippery on hard surfaces. If beads leak on to the floor, immediately clean them up with a damp cloth, and contact Hill-Rom.
- **Warning**—If topicals such as petroleum based or silver compounds are being used, use a protective material to prevent the transfer of the topicals on to the filter sheet and beads.
- **Warning**—If petroleum based compounds contaminate the beads, make sure air fluidization operates as intended. If air fluidization is affected, remove the patient from the bed and contact Hill-Rom.
- **Warning**—To help prevent poor air fluidization and protect the beads, use absorbent material or the Impervious Sheet from Hill-Rom beneath excessively incontinent or draining patients. Use the Impervious Sheet only after clinical or Hill-Rom recommendation.
- **Warning**—The Impervious Sheet may be used to block airflow from the bed to the patient. The Impervious Sheet covers the bead section of the bed and is completely impervious to moisture and air. Use the Impervious Sheet only after clinical or Hill-Rom recommendation.
- **Warning**—Air fluidization is affected by the environment, which includes room temperature and humidity, and the amount of fluid that passes through the filter sheet. Poor air fluidization can be caused by restricted air circulation from blankets and pillows on the bed or recent fluid ingress into the beads. If air fluidization is sluggish or uneven, and **not** caused by blankets and pillows on the bed or recent fluid ingress into the beads, contact Hill-Rom.
- **Warning**—To maintain optimum air fluidization, protect the beads from excessive fluid exposure.

FILTER SHEET (B)

The loose-fitting filter sheet separates the air fluidized beads from the patient and moves freely with the patient through the beads. It permits the body to sink into the beads until buoyancy is reached. The filter sheet is permeable to the same warm airflow that fluidizes the beads. This airflow gently circulates around the patient's skin, to help keep the patient warm and dry.

Always use a full-size flat bed sheet to separate the patient from the filter sheet. Hill-Rom can change the filter sheet based upon the needs of the patient and the facility. Contact Hill-Rom to have the filter

sheet changed. Between filter sheet changes, wipe off stains and residue (refer to “Cleaning and Disinfecting” on page 73).

Do not pin or clamp items to the filter sheet. Keep the bed sheet loose around the patient.

Periodically, pull the filter sheet from each side of the bed to help the patient to float freely.

Hill-Rom will replace a damaged filter sheet. Contact Hill-Rom as soon as a leak occurs. However, do these to **temporarily** repair a damaged filter sheet:

1. Find the hole or tear.
2. Turn off air fluidization.
3. Use a damp cloth to wipe away the beads from the sheet, bed, and floor.
4. When the sheet is dry, use an adhesive tape to seal the hole.
5. Turn on air fluidization.



WARNING:

Warning—The filter sheet is attached to the air wall with a sunken, zipper-like seal to prevent the beads from patient contact. If the zipper-like seal becomes loose, remove the patient from the bed and contact Hill-Rom. For additional warnings in regard to bead use, refer to “Air Fluidization Therapy Beads (A)” on page 19.



CAUTION:

To help prevent equipment damage, obey these **cautions**:

- **Caution**—Make sure the filter sheet is not damaged by abuse. Protect the filter sheet from tears caused by unprotected x-ray plates or sharp objects and pinholes that can cause bead leaks. To prevent tears in the filter sheet from sharp edges, put x-ray plates in pillowcases.
- **Caution**—Do not permit patients to smoke while in the bed; cigarette burns could cause bead leaks.

PRESSURE REDISTRIBUTION THERAPY CUSHIONS (C)

The cushions support the patient’s head, shoulders, and back. The bed delivers Pressure Redistribution therapy to this area by controlling the escape of air and pressure distribution in the inflatable cushions. The air is automatically adjusted for the patient’s weight, as well as changes in the patient’s position and head elevation. The patient receives support according to the individual’s comfort at therapeutic pressures.

NOTE:

You can adjust the cushions for comfort based on patient needs through the pendant (see page 27) and through the Bed Therapy Menu on the GCI (see page 52).

If there is a loss of power to the bed, Pressure Redistribution therapy will stop; however, the cushions will stay inflated for approximately two hours, but may not deliver pressures at the therapeutic levels set for the patient.

CLEAN ENVIRONMENT

The filter sheet is permeable to the downward flow of body fluids, such as wound drainage, perspiration, and urine. These fluids pass through the filter sheet and enter an environment that is hostile to bacterial growth.

This environment is created in this way:

1. As body fluids come into contact with the beads, the beads clump.

2. The clumps give off sodium ions, and the pH of the clump rises to approximately 9 or 10, which creates an alkaline environment. The continuous circulation of warm air creates a dry crust around the clumps.
3. Since the clumps are heavier than free-floating beads, the clumps fall to bottom of the air fluidization tank and away from the patient.
4. Hill-Rom can change the filter sheet and lift out the sieve screen to remove the clumps as needed to maintain air fluidization. Contact Hill-Rom to have the filter sheet changed and/or the clumps removed.

POINT OF CARE® BED CONTROLS

The bed has caregiver control panels in three locations: on the footboard and on both head-end sides.



WARNING:

To help prevent injury and/or equipment damage, obey these **warnings**:

- **Warning**—Mechanical parts under the bed pose a risk of serious injury. Exercise control over visitors, especially children, to keep people out from under the bed and prevent unauthorized access to the bed articulation controls.
- **Warning**—Before you articulate the bed, make sure of these:
 - The patient’s extremities are in a position so that the patient does not get injured.
 - Persons, objects, medical lines, devices, and cables from the pendant and other equipment are away from the bed’s moving parts.
- **Warning**—Lock out the bed articulation controls when patients, caregivers, or family members must be kept from inadvertently activating the bed functions.

LOCKOUT

The Lockout control disables the bed’s articulating function (for both patient and caregiver).



Lock—at the same time, press the **Lockout** control and the **Up** or **Down** control of the applicable function. Both patient and caregiver controls are locked out. A single beep sounds and the applicable indicator light comes on to let you know that the function is locked out.

Unlock—at the same time, press the **Lockout** control and the **Up** or **Down** control of the applicable function. Both patient and caregiver controls are unlocked. A single beep sounds and the applicable indicator light turns off to let you know that the function is no longer locked out.

NOTES:

- If you press the Lockout control and do not press an Up or Down control within a few seconds, or if you do not complete the lockout procedure correctly, the bed will sound a triple beep to let you know that the function is not locked out.
- If you attempt to use a locked out control, a triple beep will sound to notify you to check the lockouts.
- When CPR is activated, any controls that are locked out will become unlocked.
- Follow your facility's protocols for lockouts to reduce the likelihood of unauthorized use of the bed controls.

HEAD UP AND DOWN

The Head Up/Down control adjusts the head section to specific angles. The maximum travel for the head section is 60°.



WARNING:

Warning—Make sure the patient is in the correct position in the bed before you raise the head section. Failure to do so could cause injury.

Raise—press and hold the **Head Up** control until the bed is at the desired height.

Lower—press and hold the **Head Down** control until the bed is at the desired height.

NOTE:

The bed provides optimum pressure redistribution when the head section is at an angle of 30° or less.



BED UP AND DOWN

The Bed Up/Down control adjusts the bed height.

Raise—press and hold the **Bed Up** control until the bed is at the desired height. You will hear a single beep when the bed is at its highest position.



WARNING:

Warning—Make sure no person or equipment is under the bed when you lower it. Failure to do so could cause the person or equipment to be crushed.

Lower—press and hold the **Bed Down** control until the bed is at the desired height. You will hear a single beep when the bed is at its lowest position.

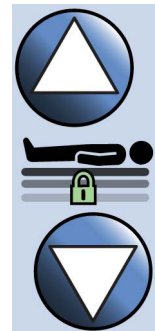

WARNING:

Warning—It is recommended that the bed be in the low position when the patient is unattended. This may reduce the severity of any resultant injuries from patient falls.

BED THERAPY (AIR FLUIDIZATION)

The Bed Therapy control turns **air fluidization** therapy on and off. When the indicator next to the control is **on**, the bed is providing therapy. When the light is **off**, the bed is not providing therapy.

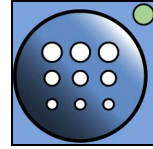

To adjust the air fluidization settings, refer to “Bed Therapy” on page 52.

For more detailed information about the air fluidization beads, refer to “Air Fluidization Therapy Beads (A)” on page 19.



WARNING:

To help prevent injury and/or equipment damage, obey these **warnings**:

- **Warning**—A patient should not remain on the bed with air fluidization not operating for more than two hours.
- **Warning**—To help prevent even short-term pressure on to a wound site, keep air fluidization **on**.
- **Warning**—Air fluidization is affected by the environment, which includes room temperature and humidity, and the amount of fluid that passes through the filter sheet. Poor air fluidization can be caused by restricted air circulation from blankets and pillows on the bed or recent fluid ingress into the beads. If air fluidization is sluggish or uneven, and **not** caused by blankets or pillows on the bed or recent fluid ingress into the beads, contact Hill-Rom.
- **Warning**—Use of materials of good thermal conductivity, such as water, gel, and similar substances with the Bed Therapy turned off could decrease the temperature of the patient.

Turn Bed Therapy On and Off

To turn air fluidization **on** or **off**, press the **Bed Therapy** control. For Bed Therapy messages that may show on the GCI, see page 55.

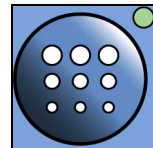

NOTES:

- **For post-operative surgical flap closures and skin graft patients**—when you transfer the patient on to the bed, it is recommended that the patient’s position is such that the patient is lying in the bed on a **non**-surgical site. This will help protect the surgical site during transport when the beads are not fluidizing because the bed is unplugged.
- If the airflow becomes insufficient and the bed can not maintain the correct airflow for air fluidization, a triple beep sounds repeatedly and either a Surface Fault or Communication Lost message shows on the GCI. Contact Hill-Rom.
- It may be helpful to have air fluidization off to hold the patient in a turn position for dressing changes and when you transfer the patient out of the bed. Refer to the pages shown below for guidance to do these tasks:
 - “Turn the Patient for Side Lying with a Pillow” on page 61
 - “Turn the Patient for Linen Changes” on page 62
 - “Turn the Patient for Back, Wound, and Perineal Care” on page 63
 - “Adjust the Female Patient’s Position for Catheterization” on page 64
 - “Adjust the Patient’s Position for Bedpan Use” on page 65

SURFACE TRANSFER

The Surface Transfer control turns the Surface Transfer mode on and off. This mode helps you to more easily move a patient laterally from one flat surface to another, such as a bed, stretcher, X-ray table, or operating room table.



When you press the **Surface Transfer** control, these occur:

- The head and back cushions Max Inflate.
- Air fluidization stops.
- The outer air wall softens.
- The **Surface Transfer** indicator on the control panel turns green to let you know that the mode is active.

NOTE:

If the Surface Transfer mode is not turned off within 30 minutes of activation, an alert sounds and this message shows on the GCI. You have the option to Continue or Cancel the mode.

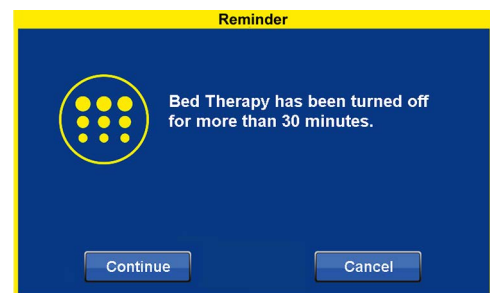

WARNING:

Warning—Use a minimum of two caregivers to transfer a patient on to the support surface. Failure to do so could cause patient or personal injury.

Transfer a Patient On to the Bed from a Bed, Stretcher, or other Flat Surface

1. Set the brake.
2. Press the **Surface Transfer** control. The side bladders will soften, and if Bed Therapy is on, the beads will level as air fluidization stops.

NOTE:

For post-operative surgical flap closures and skin graft patients—when you transfer the patient on to the bed, it is recommended that the patient's position is such that the patient is lying in the bed on a **non-surgical** site. This will help protect the surgical site during transport when the beads are not fluidizing because the bed is unplugged.

3. Adjust the height of the bed so that it is level with the other surface.
4. Put a full-size flat bed sheet on the bed.
5. Transfer the patient into the bed per facility protocol.
6. Make sure the patient's position is such that the patient's hips are aligned with the hip indicator on the bed.
7. Press the **Surface Transfer** control to turn off the mode. The **Surface Transfer** indicator turns off, the pressure in all cushions automatically adjust to the set levels, and if Bed Therapy was on before the transfer, the beads fluidize.
8. If Bed Therapy was off before the transfer, press the **Bed Therapy** control to turn air fluidization **on**.
9. Gently pull the Filter sheet loosely around the patient's body for optimal flotation in the bead section of the bed.

Transfer a Patient Out of the Bed to another Bed, Stretcher, or other Flat Surface

1. Set the brake.
2. Adjust the height of the bed so that it is level with the other surface.
3. To reduce shear and friction during the transfer, loosen the bed's filter sheet so that it moves freely with the patient.
4. Use the flat bed sheet to gently float and slide the patient to the side of the bed where the patient will exit.
5. With a caregiver on each side of the bed, use the flat bed sheet to help gently **lift** the patient's lower torso and legs up and out of the beads.
6. When the patient's lower torso and legs are lifted, use the **foot control** to turn **air fluidization off**.

NOTE:

Lifting the patient's lower torso and legs allows the beads to float upward and provide a flatter surface for easier transfer as air fluidization stops. If you do not do this, the patient's lower torso and legs may sink down into the beads which will make it harder to laterally transfer the patient out of the bed.

7. Press the **Surface Transfer** control. The outer air wall will soften, and the head and back cushions will Max-Inflate to help make the transfer easier.

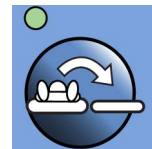

8. Transfer the patient out of the bed per facility protocol.

SIDE TRANSFER

The Side Transfer control turns the Side Transfer mode on and off. This mode makes it easier for a patient to sit on the side of the bed to get into and out of the bed from a seated or standing position.

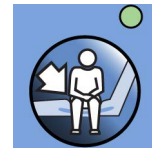

When you press the **Side Transfer** control, these occur:

- The cushions in the hip/seat section of the side bladder deflate.
- Air fluidization stays on for approximately 30 seconds so that the patient can be moved into the correct position at the side of the bed.
- An alert sounds, and air fluidization turns off.
- The **Side Transfer** indicator on the control panel turns green to let you know that the mode is active.

NOTE:

If the Side Transfer mode is not turned off within 30 minutes of activation, an alert sounds and this message shows on the GCI. You have the option to Continue or Cancel the mode.

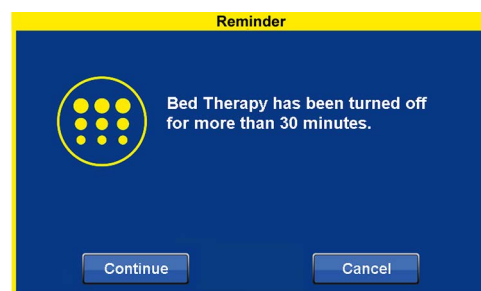

Transfer a Patient On to the Bed from a Standing or Chair Position

1. Set the brake.
2. Press the **Side Transfer** control. Within 30 seconds, you will hear a single beep to confirm that the cushions in the hip/seat section are deflated and air fluidization is off.
3. Adjust the height of the bed so that it is appropriate for the patient per facility protocol.
4. Put a full-size flat bed sheet on the bed.
5. Adjust the head of the bed for patient comfort to get into the bed.
6. Transfer the patient into the bed per facility protocol.
7. Make sure the patient's position is such that the patient's hips are aligned with the hip indicator on the bed.
8. Press the **Side Transfer** control to turn off the mode. The **Side Transfer** indicator turns off, the pressure in all cushions automatically adjust to the set levels, and if Bed Therapy was on before the transfer, the beads fluidize.
9. If Bed Therapy was off before the transfer, press the **Bed Therapy** control to turn air fluidization on.
10. Gently pull the Filter sheet loosely around the patient's body for optimal flotation in the bead section of the bed.

Transfer a Patient Out of the Bed to a Side-Sitting Position for Standing or Placement into a Chair

1. Set the brake.
2. Adjust the height of the bed so that it is in the lowest bed height appropriate for the patient per facility protocol.
3. Adjust the head of the bed for patient comfort to get out of the bed.
4. To reduce shear and friction during the transfer, loosen the bed's filter sheet so that it moves freely with the patient.
5. Use the flat bed sheet to gently float and slide the patient to the side of the bed where the patient will exit.
6. With a caregiver on each side of the bed, use the flat bed sheet to help gently **lift** the patient's lower torso and legs up and out of the beads.
7. When the patient's lower torso and legs are lifted, use the **foot control** to turn **air fluidization off**.

NOTES:

- Lifting the patient's lower torso and legs allows the beads to float upward and provide a flatter surface for easier transfer as air fluidization stops. If you do not do this, the patient's lower torso and legs may sink down into the beads which will make it harder to sit the patient up on the edge of the bed.
 - If the patient is able to use the overhead Patient Helper, instruct the patient to lift their hip and buttocks up as the beads stop fluidizing.
8. Press the **Side Transfer** control. Within 30 seconds the cushions in the hip/seat section will deflate.

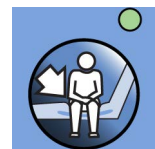

- Assist the patient into the side-sitting position, and transfer the patient per facility protocol.

NOTE:

The Side Transfer mode is intended to help make transfers into and out of the bed easier. The mode is not intended for prolonged side-sitting.

FOOT CONTROL FOR BED THERAPY (AIR FLUIDIZATION)

A foot control is on each side of the bed. The control provides a hands-free method to turn air fluidization on and off. This is helpful when you need to help the patient turn on to his/her side for dressing and/or linen changes.

Press the control with your foot to turn air fluidization to the opposite state that it is in: **off** or **on**.

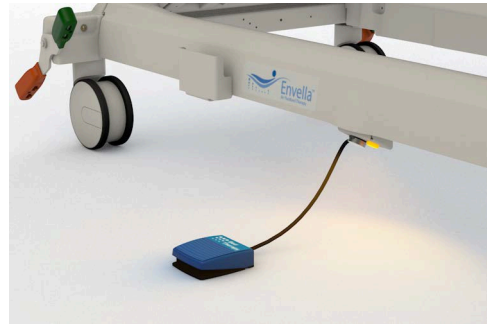

Stow the foot controls in their holders before you move the bed and when you are not using the controls.

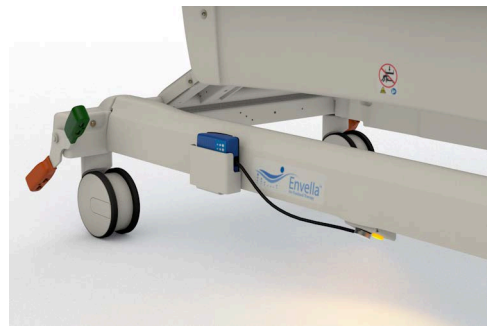
**WARNING:**

Warning—Take care to minimize the risk of tripping over the foot control cords by carefully locating them where they will not cause a trip hazard.

PENDANT (HAND CONTROL)

The pendant includes controls for head elevation and low back, upper back and head comfort.

Adjust the Head Elevation

To raise—press and hold the **Head Up** control (A) until the bed is at the desired height.

To lower—press and hold the **Head Down** control (A) until the bed is at the desired height.

To Adjust the Comfort Settings for the Low Back, Upper Back, and Head Comfort

- Press the **Zone** control (B) until the applicable indicator (Low Back, Upper Back, or Head) comes on.
- Continuously press and release the **Soft** (-) or **Firm** (+) control (C) until you reach the applicable comfort level. As you press the control, an indicator turns on to show the firmness level.

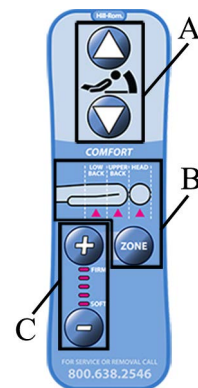



WARNING:

Warning—Put the pendant in a location where it will not cause a tripping hazard, get tangled in equipment, or get wrapped around the patient’s head or neck. Failure to do so could cause injury or damage.

GRAPHICAL CAREGIVER INTERFACE (GCI)[®] CONTROLS

The GCI is on the footboard. Through the GCI, you can do these:

- View helpful information for the bed functions.
- Set Bed Exit and Head Angle Alerts.
- Preemptively silence the Bed Exit Alert.
- Zero the scale.
- Weigh the patient.
- Adjust the Bed Therapy settings.
- Set a Turn Reminder.
- Review the history for the different bed functions.
- Adjust the GCI’s date and time.



UNLOCK THE GCI

1. Touch the screen.
2. Slide your finger across the screen at the location shown.

The screen will dim after 1 minute of not being touched. After 2 minutes of the screen not being touched, the screen will lock. When locked, the screen information will still be visible, but for use, the screen will need to be unlocked.



LOCK THE GCI

To hide the screen information, press the **Lock** control in the lower left corner of the screen. The swipe screen will show until the screen is unlocked.

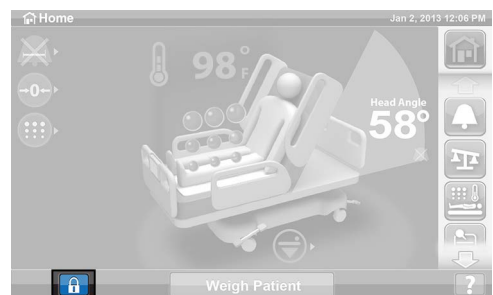

USE THE GCI MENU CONTROLS

As you use the GCI's menu controls and view the different screens, you can always press the **Home** menu control to return to the Home screen.

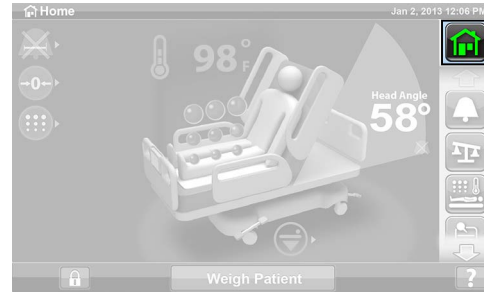

To access hidden menu controls, use the scrolling menu's **Up** and **Down** controls or slide your finger up and down on the menu.

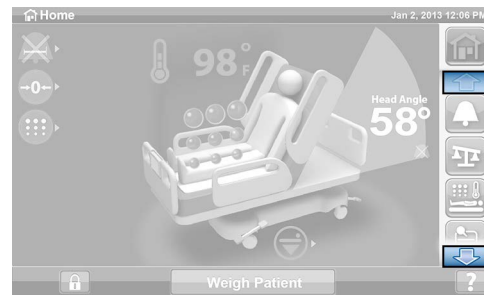

To return to the previous screen, press the **Return** control.



To see more detail associated with the Status indicators that are on the left side of the screen and the Bed Height indicator, touch the applicable indicator.

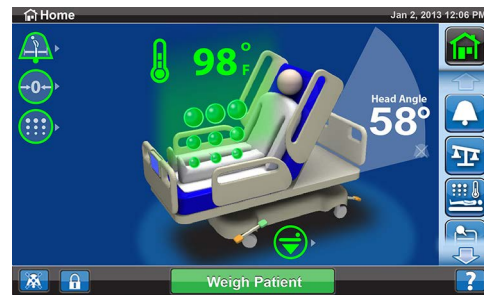

Screens with red or yellow borders identify warning and caution situations:

- Red = warning

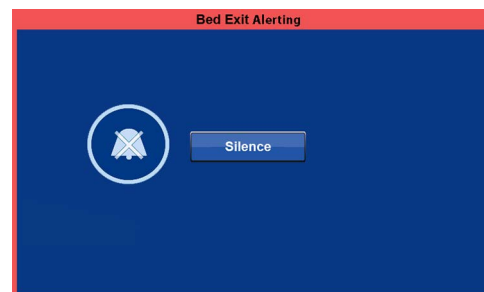

- Yellow = caution



ACCESS THE HELP (?) MENU

Through the Help menu control, you can access additional instruction for many of the bed functions and features along with a digital version of the bed's user manual.

1. Press the Help control on the GCI.

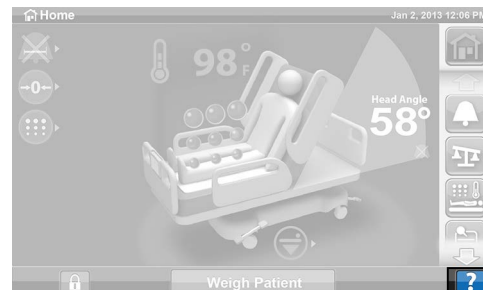

2. Press the control for the subject that you want to view.

ALERTS

Through the Alerts menu control you can set the Bed Exit Alert and the Head Angle Alert.

Bed Exit Alert

The Bed Exit Alert sounds an alert when 25 lb to 35 lb (11.3 kg to 15.9 kg) of the patient's weight shifts off the frame of the bed. This mode is most useful when a caregiver wants the patient to move freely within the bed, but to be notified when the patient leaves the bed.

When the system is armed and it detects an Out-of-Bed alert condition, these occur even if the patient returns to the bed:

- An audible alert comes on.
- The Bed Exit Alerting screen shows on the GCI.

NOTE:

The Bed Exit Alert System should be used in conjunction with a sound falls-risk assessment and facility approved protocol.

When the Bed Exit Alert is **on**, it sounds in these situations:

- The patient exits the bed.
- A siderail is removed or replaced.

Turn the Bed Exit Alert On

1. Make sure the patient is centered on the bed and aligned with the hip locator.
2. Press the **Alerts** menu control.

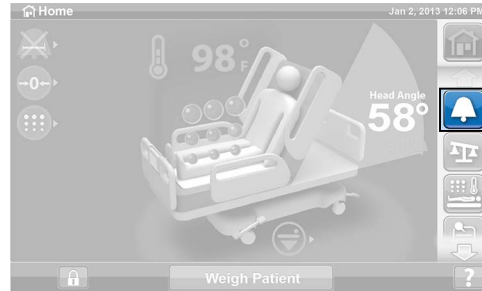

3. Press **Bed Exit**.

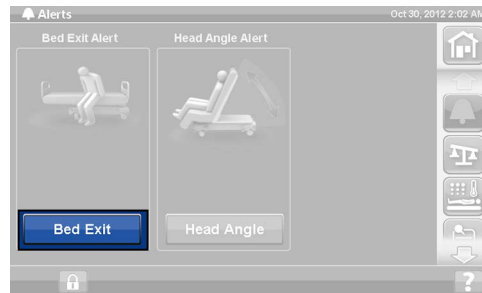

4. Press **Out of Bed**.

NOTE:

At this screen, you can also access the screen that lets you change the alert volume and tone (see “Change the Alert Volume” on page 40).

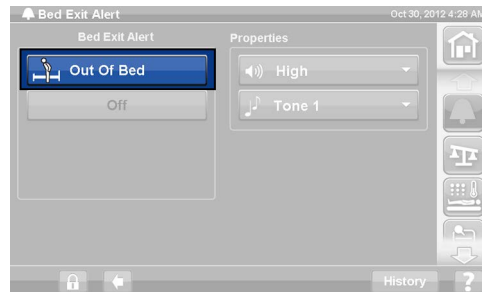

5. A confirmation message shows. Press **OK**.

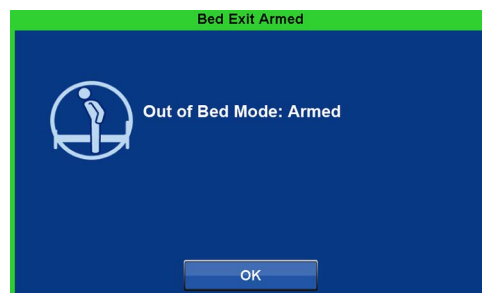

The Home screen shows, and the Alert Status indicator is green.

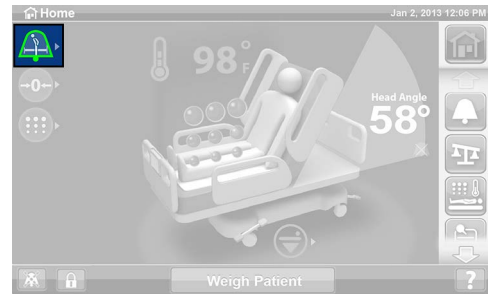

Turn the Bed Exit Alert Off

1. Press the **Alerts** menu control.

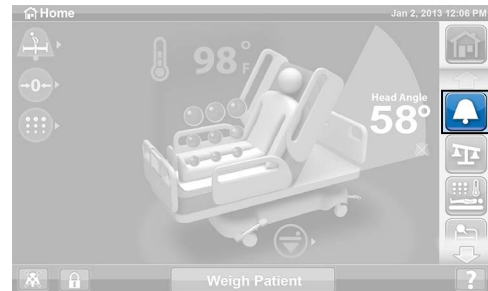

2. Press **Bed Exit**.

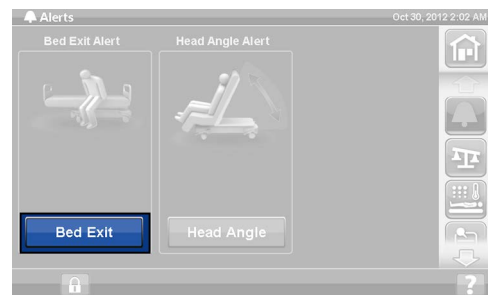

3. Press **Off**.



4. A confirmation message shows. Press **Yes** to confirm.



The Alerts screen shows.



At the Home screen, the Alert Status indicator has an "X" through it and is no longer green.

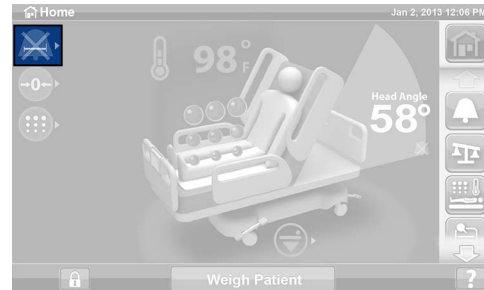

Silence the Bed Exit Alert without Deactivating the System

When the Bed Exit mode is armed, you can silence the alert system. During this Silence mode, the system stops monitoring the patient movement; therefore, the system does not turn on the audible alert. While the system is in the Silence mode, you can change the position of the patient or assist the patient out of the bed. You can silence the alert before it sounds (preemptively) or after it sounds.

Once the alert silence is activated, you have 30 seconds to either have the patient exit the bed or return to the correct position for Bed Exit to arm.

- If the patient exits the bed, the alert will not sound. The Bed Exit Alert will not re-arm until the patient returns to the bed.
 - After the patient has returned to the bed, the patient must be returned to the center of the bed for the Bed Exit Alert to re-arm.
1. **To silence the alert system before it sounds**—press the **Preemptive Alert Silence** control at the lower left of the GCI.

or

To silence the alert system after it sounds—at the **Bed Exit Alerting** screen, press **Silence**.

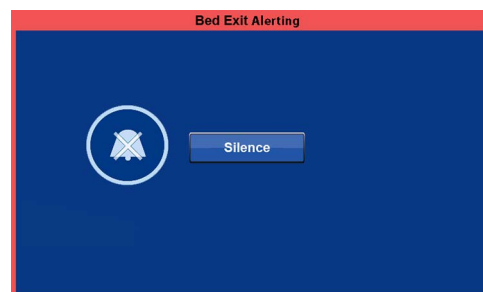
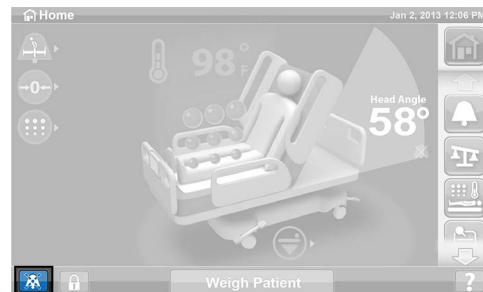

2. Press the applicable option:

- **Resume**—immediately turns the bed exit alert on.
- **Suspend**—if 30 seconds is not a long enough interval, suspend allows a default of 10 minutes additional time before the bed attempts to re-arm the alert. If the bed does not detect a patient after the time expires, the alert sounds.
- **Bed Exit Off**—turns the bed exit alert off.

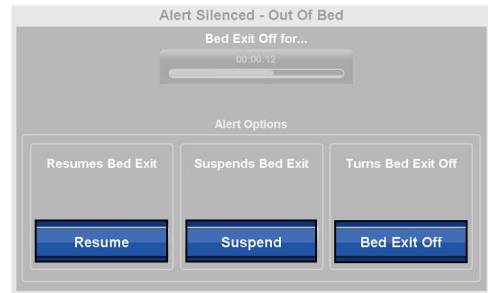

NOTE:

If you finish the task before the Suspend time has expired, reactivate the Bed Exit Alert. The Bed Exit Alert will not be active and will not convey its status until it has been reactivated.

- If you press Resume, the Home screen shows, and the Alert indicator is green.
- If you press Suspend, you will then have the option to **Resume**, **Silence**, or turn **Bed Exit Off**.
- If you press Bed Exit Off, the Home screen shows, and the Alert status indicator has an “X” through it and is no longer green.

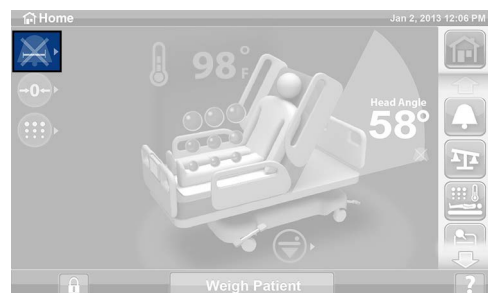
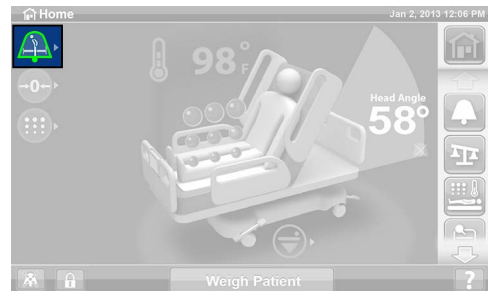

NOTE:

If you do not select an option, after the system has been in Silence mode for 30 seconds, the system will try to arm itself for the Bed Exit Alert.

View Bed Exit Alert History

The Bed Exit history shows the time spent with the Bed Exit alert on.

From the Bed Exit Alert screen, press **History**.

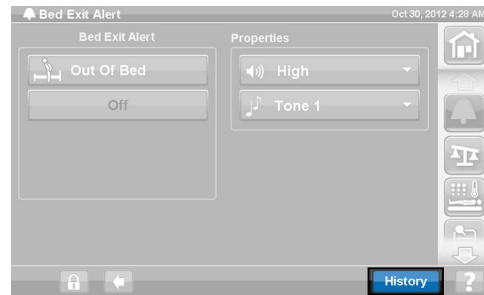

Either the **Arming History** or **Alerting History** screen shows. Press **Change View** to see the other screen.



Bed Exit Alert System Messages

If an issue occurs with the Bed Exit Alert System, a message shows on the screen and an alert sounds.

NOTE:

Follow facility protocols for Falls Risk Patients if the Bed Exit Alert System has a technical problem.

Bed Exit Alerting Warning (technical problem)—this message shows when a technical problem occurs with the feature while Bed Exit is armed.

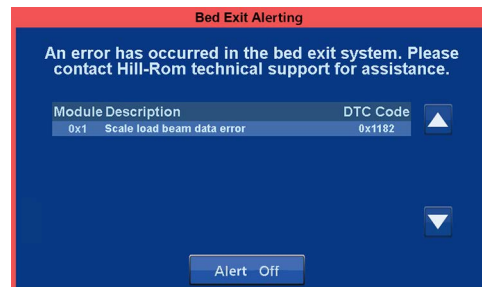

Failed to Arm Caution (technical problem)—this message shows when Bed Exit Alert will not arm because there is a technical problem with the feature.



Failed to Arm Caution (weight problem)—the **Weight Too High** and **Weight Too Low** messages show when the Bed Exit System can not arm because the patient weight is out of the 70 lb to 350 lb (32 kg to 159 kg) range. If you are certain that the patient weight is within range, zero the scale, and then try to set the alert.

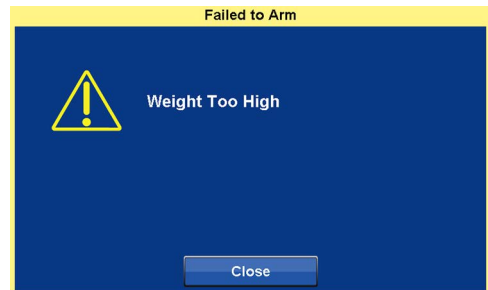

NOTE:

The bed is intended for patients who are within the specified weight limit of 32 kg to 159 kg (70 lb to 350 lb).

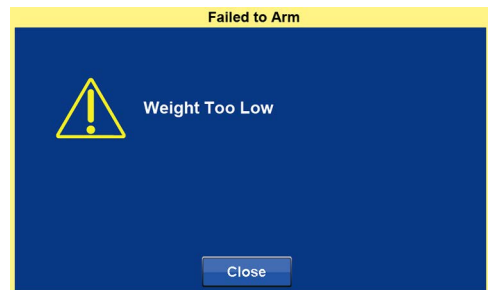

Weigh Patient Error Caution—this message shows when you attempt to arm Bed Exit and there is a problem with the Weigh Patient process. Press **OK**, and then try to arm Bed Exit.

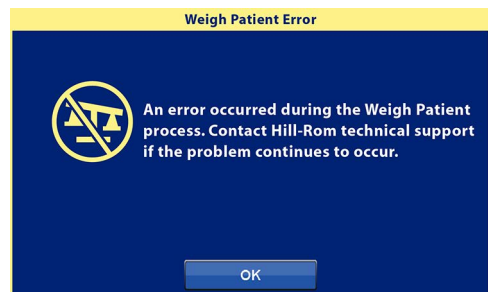

Siderail Sensor Error (latch problem)—this message show when you have attempted to use a scale or bed exit function and a siderail is not fully latched.

If the Bed Exit Alert is armed, the Alert will sound.

At the Home screen, the faulty siderail will flash.



Head Angle Alert

The Head Angle alert lets the caregiver set an alert to sound if the head section goes below 30° or 45°.

Activate the Head Angle Alert

1. Raise the head section to the applicable position **above** 30° or 45°.
2. Press the **Alerts** control on the GCI.
3. Press **Head Angle**.
4. Press the desired alert angle: **Alert Below 30°** or **Alert Below 45°**.

NOTE:

From this screen, you can also access screens that let you change the alert volume (see “Change the Alert Volume” on page 40) and view the Head Angle Alert history.

5. The applicable Head Angle Armed screen shows. Press **OK**.

The Home screen shows, and the Head Angle Alert Status is green and shows the degree of angle for the Alert.

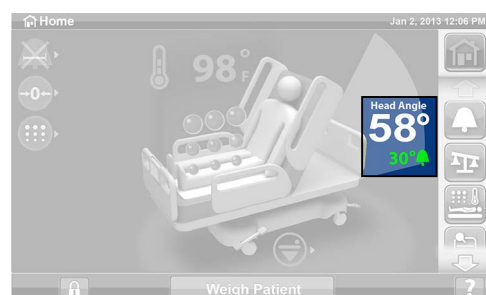
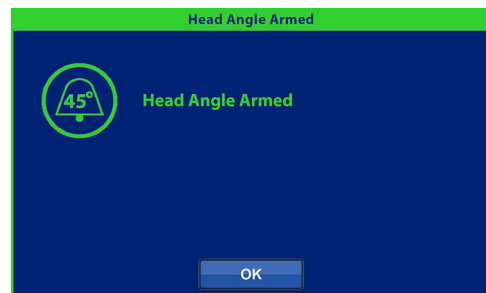
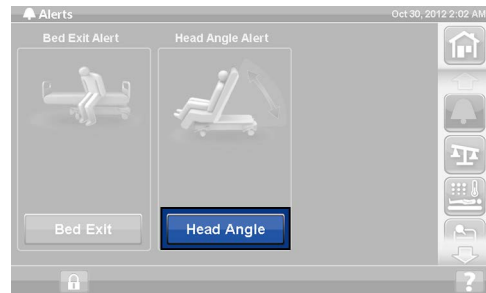
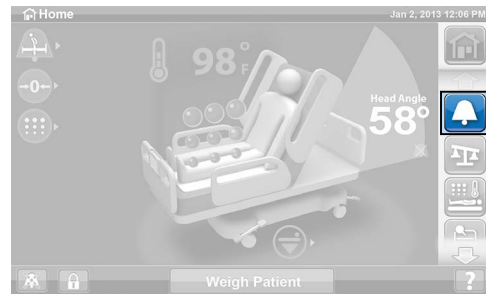

When the Head Angle Alert Sounds

When the Head Angle alert is armed, and head section goes below the alert angle, an alert sounds and the **Head Angle Alert** screen shows. Do one of these:

- Raise the head section to the applicable position above 30° or 45°.
- Press **Alert Off**. This turns off the Head Angle alert. The Home screen shows, and the Alert Status indicator has an "X" through it and is no longer green.

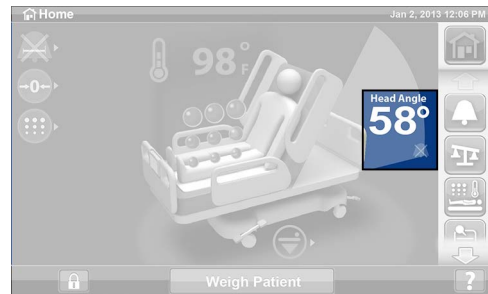

Turn Off the Head Angle Alert

1. Press the **Alerts** menu control on the GCI.

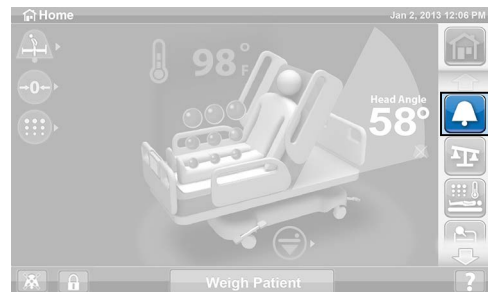

2. Press **Head Angle**.

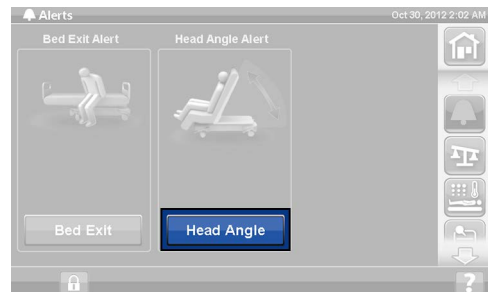

3. Press **Off**.

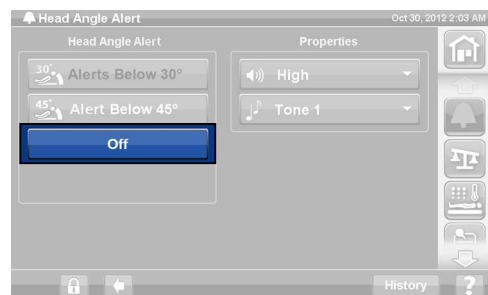

4. A confirmation message shows. Press **Yes** to confirm.

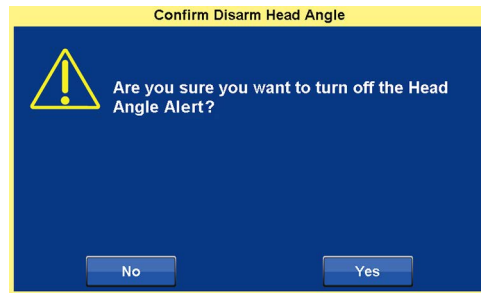

View the Head Angle Alert History

The Head Angle alert history shows the time spent with the head of bed more than 30° or 45° since 12 AM with Head Angle alert active.

From the Head Angle Alert screen, press **History**.

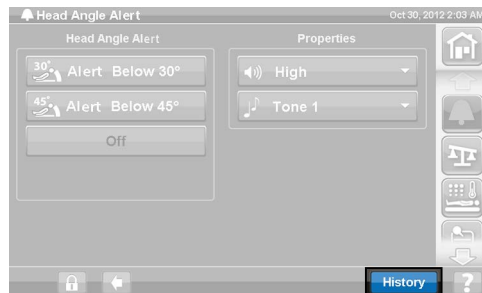

The history shows for either **Below 30°**, **Below 45°**, or **Alerts**. Depending on which screen shows, press **Below 30°**, **Below 45°**, or **Alerts** to select one of the screens.

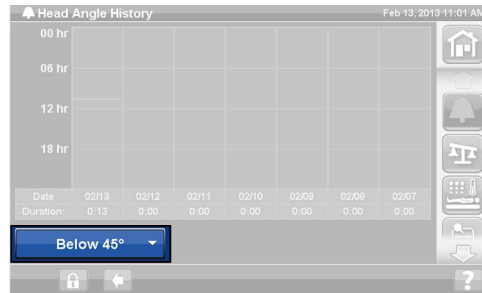

Head Angle Alert Messages

Alerts (technical problem)—this message shows when the Head Angle Alert will not arm because there is a technical problem with the feature.

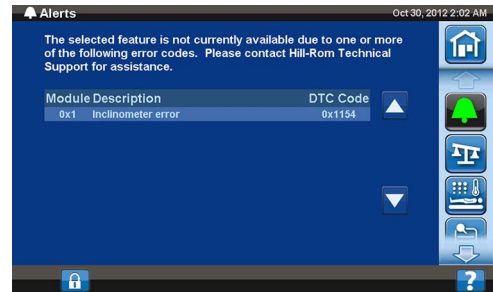

Failed to Arm Caution (technical problem)—this message shows when the Head Angle Alert will not arm because a technical problem occurred as you attempted to set the alert.

NOTE:

Make sure that the head section angle is **more than 30°** or 45°.



Change the Alert Volume

The alert volume can be changed from the default value to something softer.

1. Press the **Alerts** menu control on the GCI.
2. Press the applicable alert: **Bed Exit** or **Head Angle**.
3. From either the Bed Exit Alert or Head Angle Alert screen, press the **Volume** (High is shown) control.

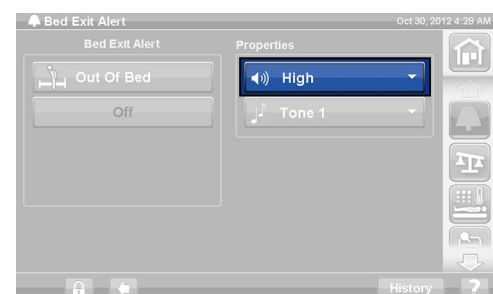
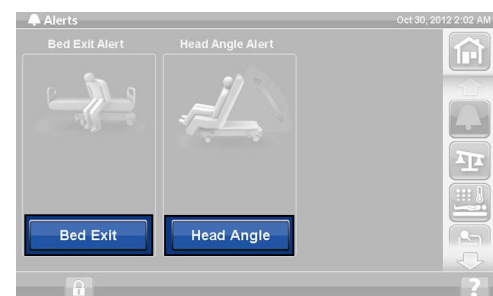
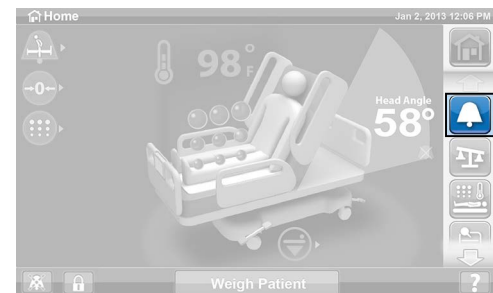

4. Press either **Low**, **Medium**, or **High**.

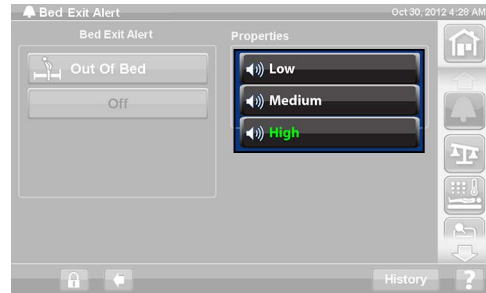

Change the Alert Tone

If you want to change the tone of the Alert, contact Hill-Rom.

SCALE

Through the Scale menu control you can do these:

- Zero the scale (does not clear history).
- Weigh the patient.
- Manually adjust the weight.
- Add or remove items on the bed and correct the weight reading while the patient is on the bed.
- Calculate BMI.
- View weight history.

Before you zero the scale or weigh the patient, make sure that the pendant is either on the siderail or footboard.

Scale Specifications

NOTE:

Scale accuracy: 2.2 lb (0.99 kg) or 1% of patient weight, whichever is greater

Scale repeatability: 2.2 lb (0.99 kg) or 1% of patient weight, whichever is greater

Weigh the Patient

NOTE:

Everything on or attached to the bed will be included in the scale reading. This includes IV poles and items attached to the poles; pumps and drainage bags; the patient helper/trapeze; and items attached to the headboard, footboard, and siderails. The bed scale will automatically account for the siderails being off or on the bed.

1. Make sure the patient is centered and laying on the bed.
2. Lower the head section so that it is below 45°.

3. Press the **Scale** menu control or **Weigh Patient** control on the GCI. If you pressed the Scale menu control, go to Step 4; if you pressed Weigh Patient control, go to Step 5.

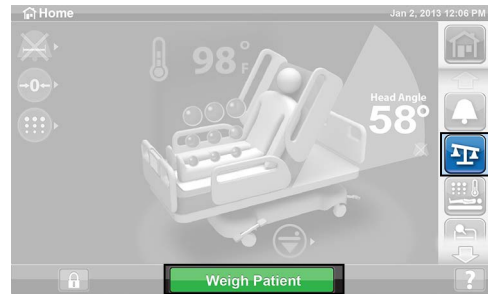

4. Press **Weigh**.



5. A reminder message shows. If the bed is as described in the message, press **Continue**.



Make sure not to touch the bed as the scale weighs the patient.

NOTE:

Bed Therapy automatically turns off during the weighing process and resumes when the process is complete.

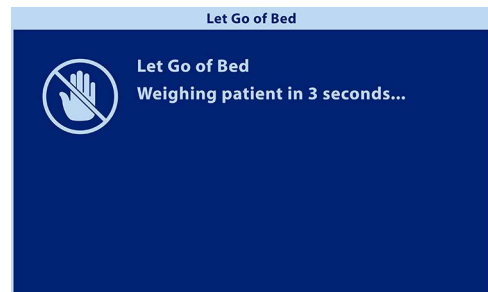

- When the New Patient Weight screen shows, press **Accept**. This will store the weight in the history.

NOTE:

If you press **Re-weigh** or **Cancel**, the Are You Sure screen will show. Re-weigh will take you back through the weighing screens. Cancel will take you to the Scale menu screen.



- A reminder message shows, do as instructed, and then press **Close**. The Scale screen shows.

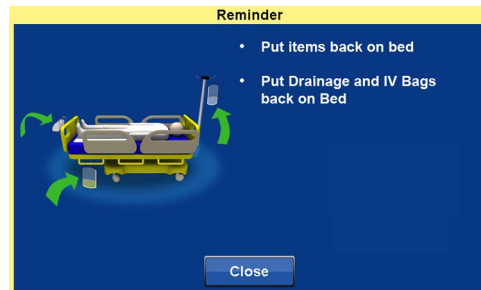

NOTE:

At this screen, you can also access the lb/kg screen that lets you change the scale units from pound (lb) to kilogram (kg), kilogram (kg) to pound (lb), or both kilogram and pound (kg/lb). Contact Hill-Rom if you would like for this option to be locked out.



View Weight History

The GCI will show the initial weight of the patient and will allow you to view the last 21 weight readings that were taken. The screen will show the date and time, last zero, the weight, and how much the weight was adjusted.

- Press the **Scale** menu control on the GCI.

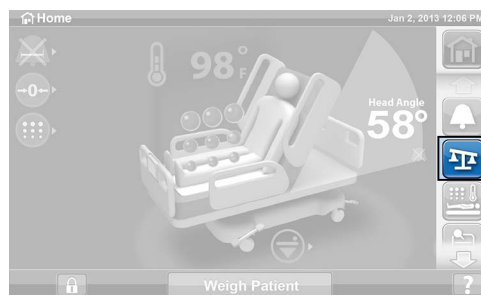

2. Press **History**.

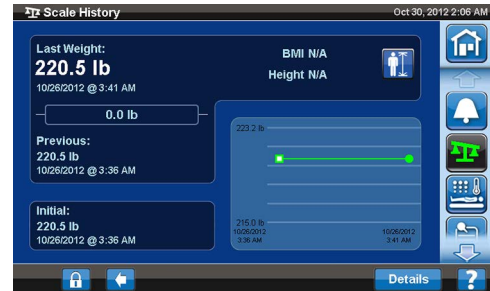

Weigh Patient Messages

Weigh Patient Error (technical problem)—this message shows when you attempt to weigh the patient and there is a problem with the Weigh Patient process. Press **OK**, and then try to weigh the patient again.

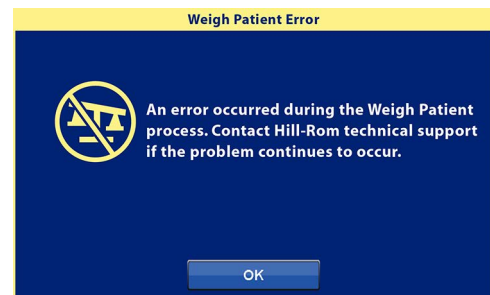

Weight Out Of Range (weight problem)—this message shows when the scale system can not weigh because of these:

- The patient weight is less than 70 lb (32 kg) or more than 350 lb (159 kg).
- The weight on the bed is not close to the initial weight (greater than 25 kg (55 lb)).
- The weight is below 0.

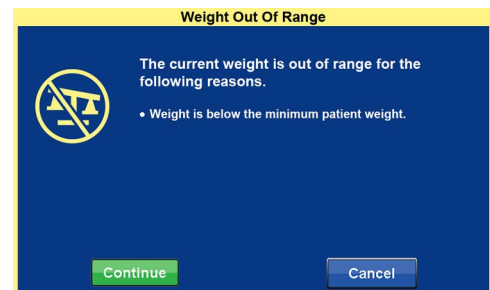

NOTE:

If you are certain that the patient weight is within the 70 lb to 350 lb (32 kg to 159 kg) range, zero the scale (see "Zero the Scale" on page 45), and then weigh the patient.

Siderail Sensor Error (latch problem)—this message shows when you have attempted to use a scale or bed exit function and a siderail is not fully latched.

If the Bed Exit Alert is armed, the Alert will sound.

At the Home screen, the faulty siderail will flash.



Zero the Scale

NOTE:

Hill-Rom Service Technicians will zero the scale upon delivery.

NOTE:

Everything on or attached to the bed will be included in the scale reading. This includes IV poles and items attached to the poles; pumps and drainage bags; the patient helper/trapeze; and items attached to the headboard, footboard, and siderails. The bed scale will automatically account for the siderails being off or on the bed.



WARNING:

Warning—Zero the scale before a new patient is put on the bed and whenever additional equipment is added to the bed. Failure to do so could cause an inaccurate weight reading; patient injury could occur.

1. Make sure the patient is **not** on the bed.
2. Lower the head section so that it is below 45°.
3. Press the **Scale** menu control on the GCI.

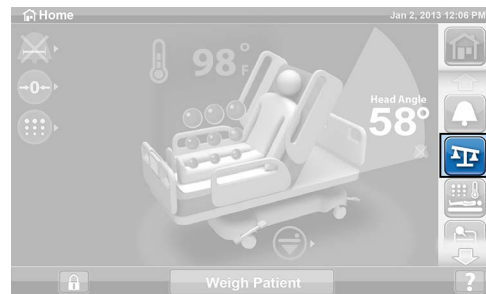

4. Press **Zero**. (This does not erase the Scale History.)



5. A reminder message shows. If the bed is as described in the message, press **Yes**.

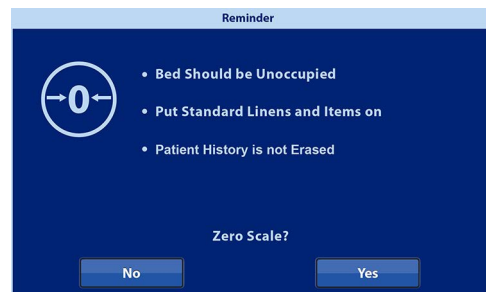

Make sure not to touch the bed as the scale zeroes.

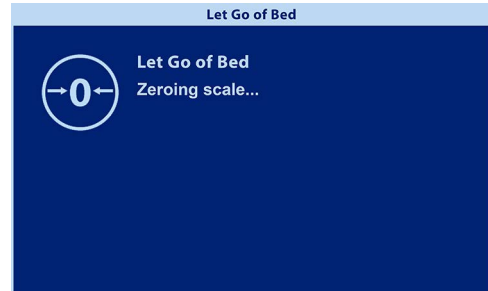
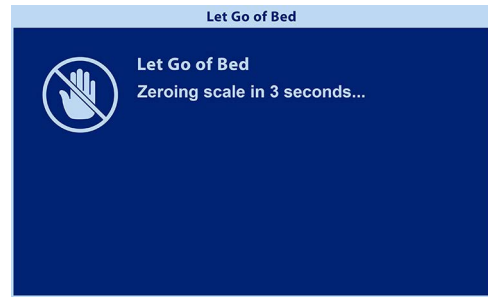

- When the Zero Complete screen shows, press **OK**. The Scale screens shows.

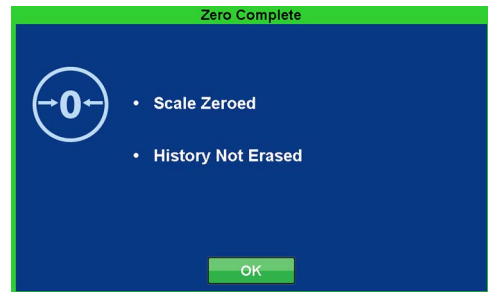

- To return to the **Home** screen, press the **Return** arrow control.



At the Home screen, the Zero Status indicator is green.



Zero Scale Messages

Weigh Patient Error (technical problem)—this message shows when an error occurs with the Weigh Patient process as you attempt to zero the scale.



Zero Disabled (technical problem)—this message shows when the Scale Zero function is not available because the Bed Exit Alert is armed.



Body Mass Index (BMI) Calculator

Body Mass Index (BMI) is a number calculated from a person's weight and height.

1. Press the **Scale** menu control on the GCI.

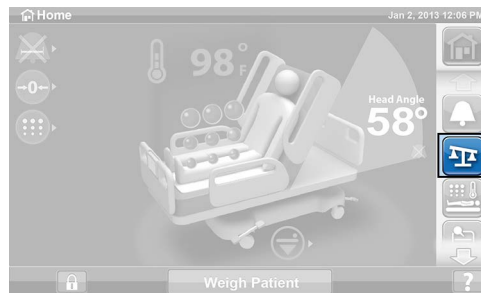

2. Press **History**.



3. Press the **Height** control.

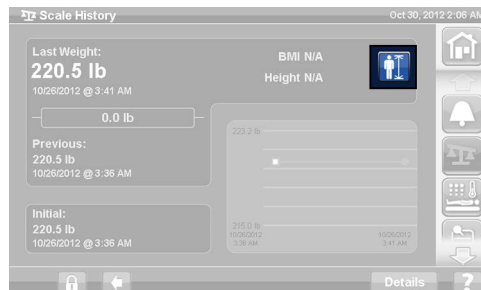

4. Enter the patient's height, and press **Accept**.

NOTE:

The height units can be changed from centimeters (cm) to inches (in).

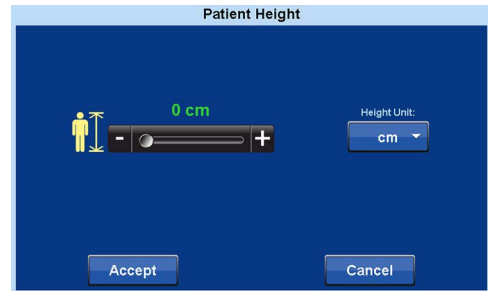

Adjust Weight

The Adjust Weight function lets you manually enter the patient's estimated weight.

1. Press the **Scale** menu control on the GCI.

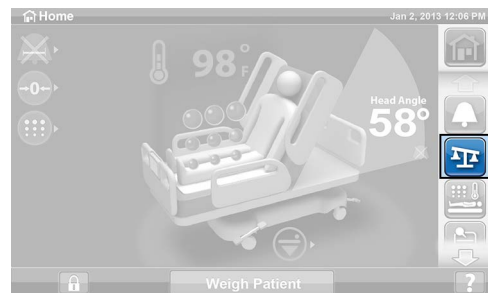

2. Press **Options**.



3. Press **Adjust Weight**.

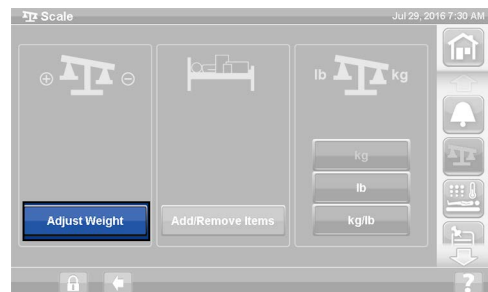

4. Enter the patient's weight, and press **Accept**.

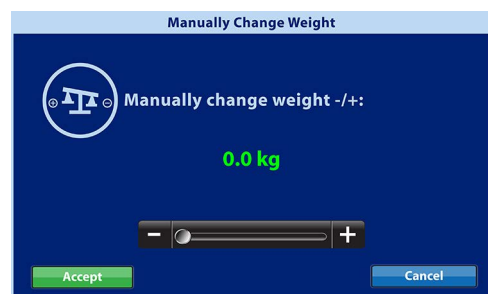

Make sure not to touch the bed as the scale weighs the patient.

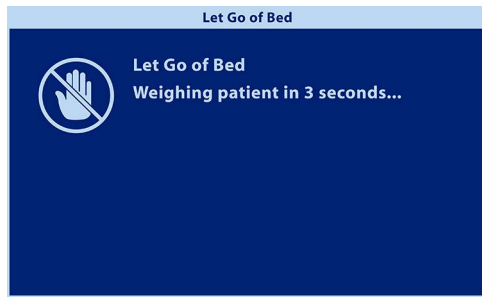

- At the Adjusted Weight screen, press **Accept**.

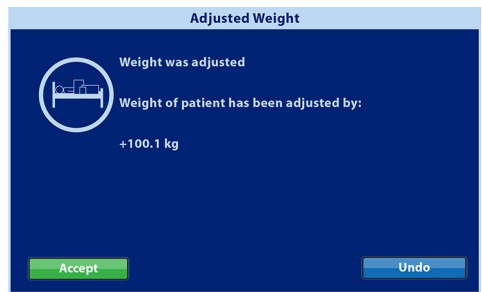

Add/Remove Items

The Add/Remove Items function lets the caregiver change items on the bed and correct the weight reading while the patient is on the bed.

- Press the **Scale** menu control on the GCI.

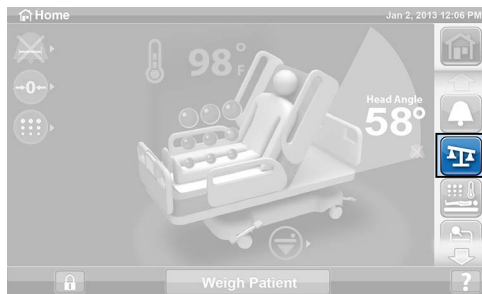

- Press **Options**.



3. Press **Add/Remove Items**.

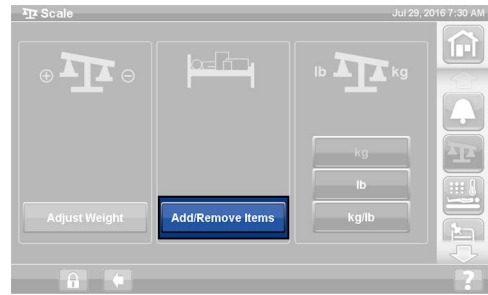

4. Press **Continue**.

Make sure not to touch the bed as the scale weighs the patient.

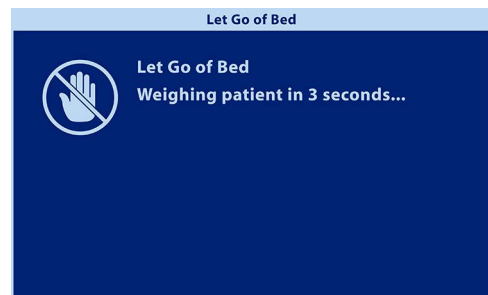
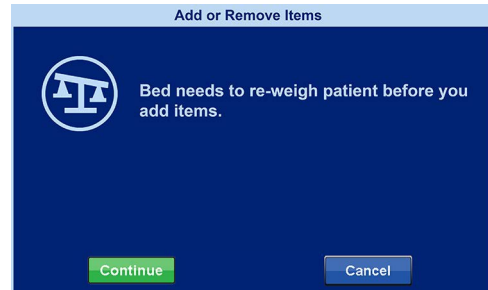

5. Add or remove items as necessary, and press **Continue**.

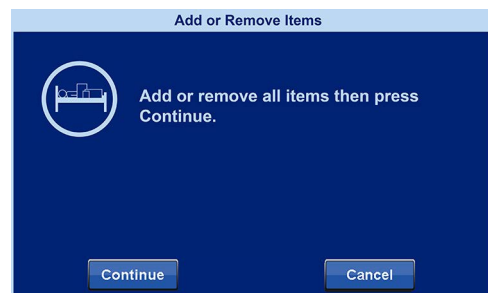

The scale will weigh the patient. Make sure not to touch the bed as the scale weighs the patient.



- At the **Items Weighed** screen, press **Accept**.

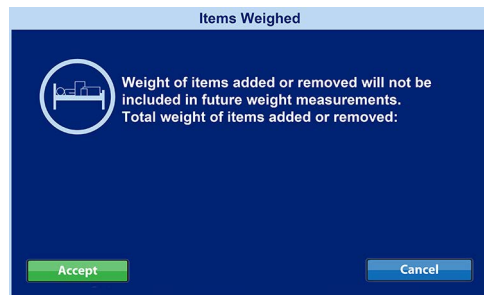

- A reminder message shows, do as instructed, and then press **Close**.



- To return to the **Scale** menu screen, press the **Return** arrow control.

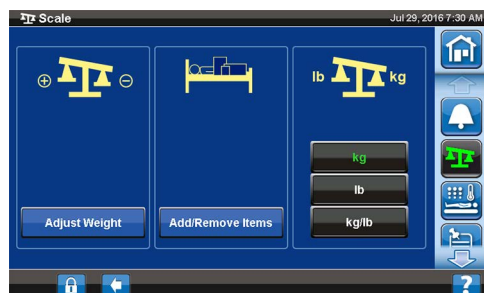

- To return to the **Home** screen, press the **Return** arrow or **Home** menu control.



BED THERAPY

Through the Bed Therapy Menu, you can adjust these features:

- The temperature in the bead section of the bed
- The intensity of the air flow in the bead section of the bed
- The firmness of the cushions in the upper section of the bed

For detailed instructions for use of the Bed Therapy feature, refer to “Bed Therapy (Air Fluidization)” on page 23.

Adjust the Comfort Level

- Press the **Bed Therapy** menu control on the GCI.

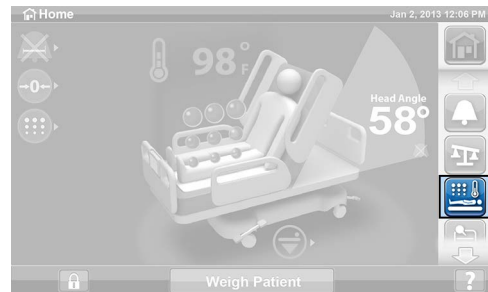

- Press **Comfort**.

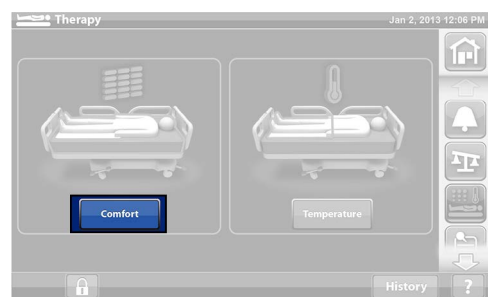

- To adjust the **intensity of the air flow** in the bead section of the bed, press the desired intensity—**Low**, **Medium**, or **High**.
- To adjust the **firmness** of the head, back, and lumbar cushions, press the **Up** (more firm) or **Down** (less firm) arrow for each of the three locations shown.

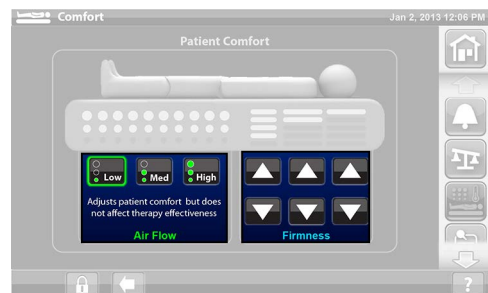

NOTE:

A Bed Therapy Not On message will show on the screen if Air Fluidization is off.

Adjust the Temperature

For best results, operate the bed in a maximum ambient room temperature of 78°F (24°C) and a maximum relative humidity level of 75%.

The temperature adjustment feature affects the bead section of the product only. The actual temperature of the bead section may vary up to 3°F (1.7°C) from the temperature setpoint.

The Temperature in the bead section of the bed can be adjusted from 86°F to 100°F (30°C to 38°C) in 1°F (.5°C) increments.



WARNING:

To help prevent injury and/or equipment damage, obey these **warnings**:

- **Warning**—Transdermal medications (patches) when warmed can increase drug delivery. This could result in possible harm to the patient.
- **Warning**—The Temperature Adjustment feature is intended for the patient's comfort only and is not intended to heat or cool the patient. However, it may affect the patient's temperature. Monitor the patient's temperature frequently.

NOTES:

- The approximate time required for the contact surface temperature to heat up from 73.4°F ± 2°F (23°C ± 2°C) to 98.6°F (37°C) when operated under conditions of adequate heat discharge is 2 to 4 hours.
- The bed operates approximately 10°F (5.5°C) higher than the ambient room temperature. If the bed can not reach the set temperature, you may need to lower the ambient room temperature.

1. Press the **Bed Therapy** menu control on the GCI.

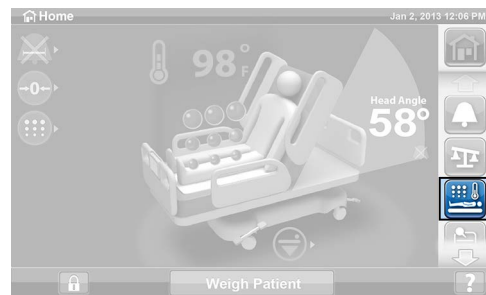

2. Press **Temperature**.

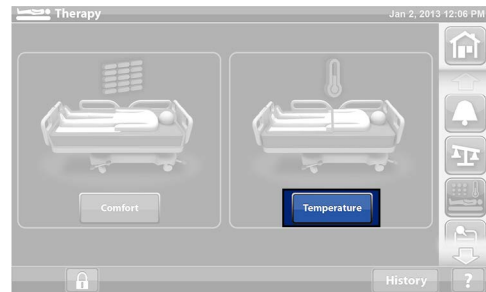

3. Set the temperature higher (+) or lower (-) as necessary.

NOTE:

To change the temperature units, press °F (or °C).

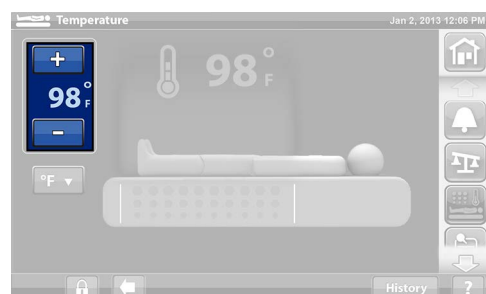

- If you set the temperature higher, the temperature elements on the GCI turn orange until the bead section reaches the set temperature.

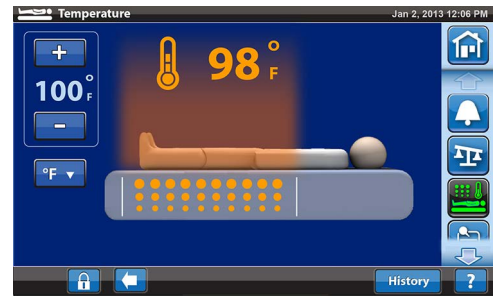

- If you set the temperature lower, the temperature elements on the GCI turn blue until the bead section reaches the set temperature.

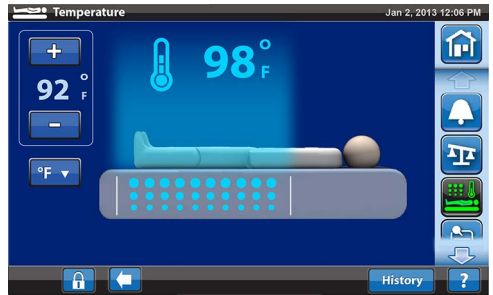

NOTE:

The temperature elements on the GCI are yellow when Bed Therapy (air fluidization) is off.

View Bed Therapy History

The Bed Therapy history shows the dates and durations for when air fluidization was in use.

1. Press the **Bed Therapy** menu control on the GCI.

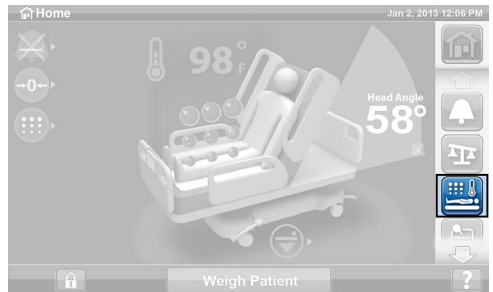

2. Press **History**.

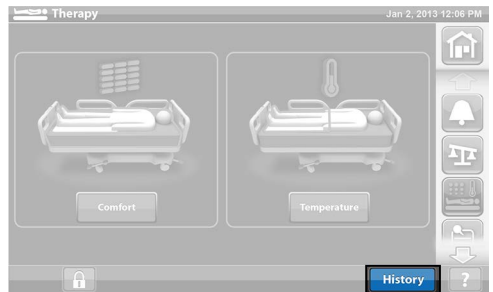

3. Press **Change View** to see a view that shows exactly when the therapy was turned off and on.

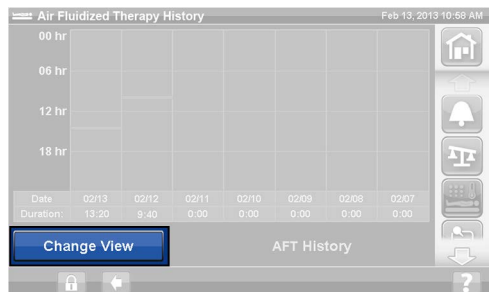

Bed Therapy—Air Fluidization and Temperature Messages

30 Minute Reminder when Bed Therapy is Off during a Transfer Mode

If the Surface Transfer or Side Transfer mode is not turned off within 30 minutes of activation, an alert sounds and this message shows on the GCI. You have the option to Continue or Cancel the mode.

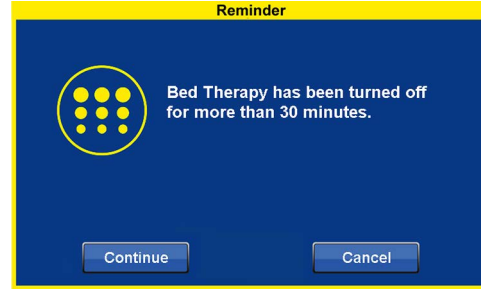

30 Minute Reminder when Bed Therapy has been Turned Off

If a patient is in the bed and Bed Therapy (air fluidization) has been turned off and it is off for more than 30 minutes, a triple beep sounds every 5 seconds and a Reminder message shows on the GCI. If you press **Silence**, and do not turn Bed Therapy (air fluidization) on, as a reminder to resume the therapy, the alert will sound again in 15 minutes. This will continue until you turn Bed Therapy (air fluidization) on or remove the patient.

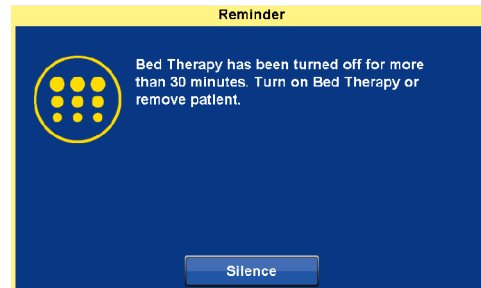

To resume air fluidization, press the **Bed Therapy** control at either the head-end side or foot-end control panel.

Bed Therapy Turned Off because of a Heat Exchanger Fan Error

When air fluidization turns off because of a fan malfunction, a triple beep sounds every 5 seconds and a message shows on the GCI. Remove the patient from the bed and contact Hill-Rom.

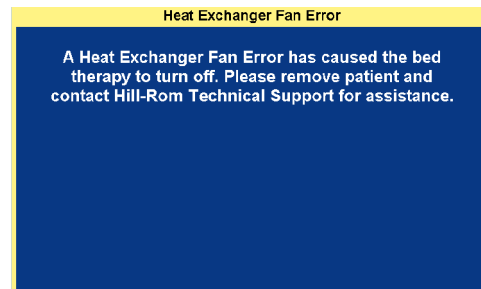

Bed not Ready—Bed Temp Too Low

When the temperature in the bead section is too low for patient placement (below 82°F or 28°C), the Bed Temp Too Low message shows on the GCI, press **Close**.

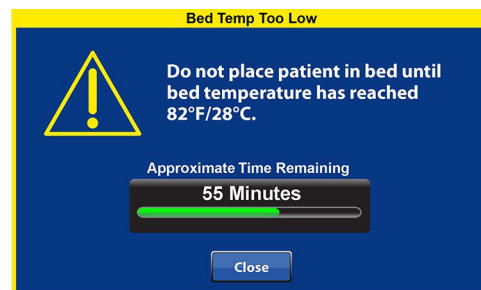

The Home screen shows with a **Low** temperature status. After 20 minutes, if the temperature still has not reached 82°F or 28°C, the Bed Temp Too Low message will show again. This will continue until the temperature in the bead section reaches 82°F or 28°C.



When the temperature in the bead section reaches 82°F or 28°C, the Bed Ready for Patient message shows. Press **Close** to return to the Home screen.

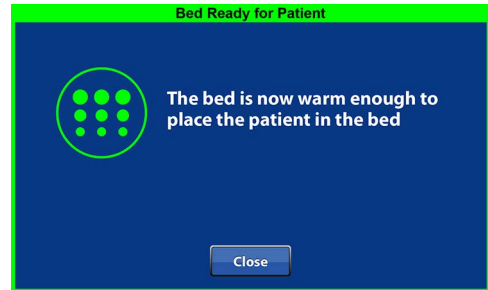

Bed Therapy System Messages

An alert (3 beeps that repeat every 10 minutes) will sound whenever one of the conditions below exist.

Temperature to Setpoint Mismatch (technical problem)—this message shows when the temperature in the bead section of the bed differs more than 3.0°F (1.7°C) from the setpoint.



Unable to Reach Temperature Setpoint (environment problem)—this message shows when the room temperature is too different from the bead section setpoint. Adjust the room temperature as necessary.

NOTE:

The bed operates approximately 10°F (5.5°C) higher than the ambient room temperature. If the bed can not reach the set temperature, you may need to lower the ambient room temperature.

Communication Lost (technical problem)

Pneumatic Control Board—this message shows when there is a communication issue with the P.C. board that controls air fluidization.

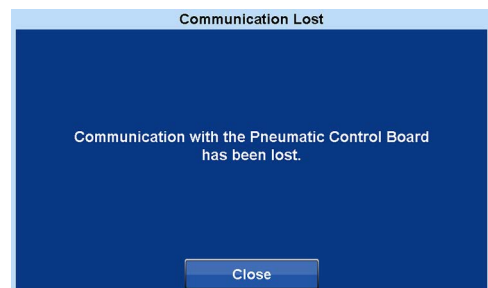

Air Control Board—this message shows when there is a communication issue with the P.C. board that controls the head, back, and lumbar cushion section.



Bed Temperature Too High / Communication Issue (technical problem)—a continuous alarm will sound and Bed Therapy will be disabled if either of these conditions occur:

- The temperature in the bead section of the bed exceeds the maximum allowable temperature.
- There is a connection issue with the temperature sensor.

If an alarm sounds, remove the patient from the bed, and contact Hill-Rom.

To turn off the alarm sound, press the **Bed Therapy** control on one of the caregiver control panels. Press the **Bed Therapy** control again to turn the sound back on.



Surface Fault (technical problem)—this message shows when the support surface will not operate correctly because there is a technical problem with the surface.

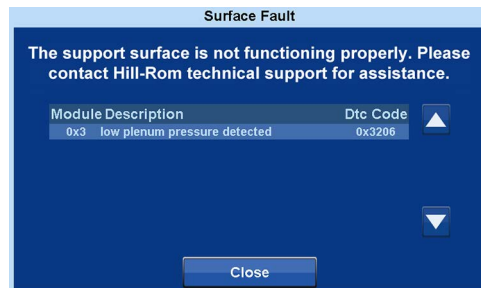

MISCELLANEOUS MESSAGES

If any of these errors occur, along with the message on the screen, you will hear 3 beeps that repeat every 10 minutes.

Articulation or Control Panel Errors (technical problem)—this message shows when there is a problem with the articulation controls or the other controls on a control panel.

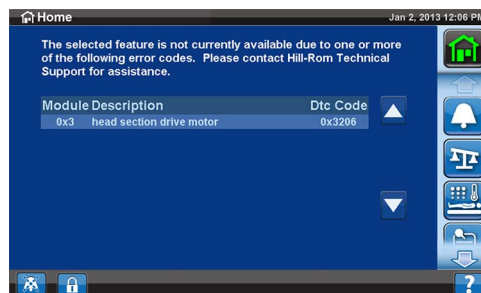

Bed Not Level Error (articulation problem)—this message shows at startup if the bed is not level.



Bed Not Level Error (technical problem)—this message shows if at startup the bed is not level and you have attempted to adjust the bed to level and the adjustment was not successful.

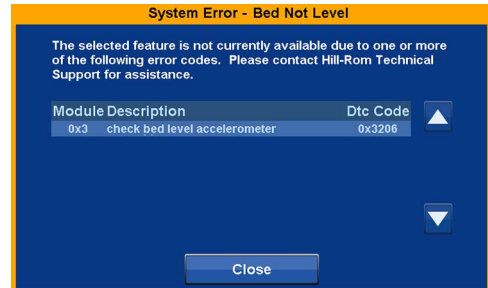

TURN REMINDER

The Reminder menu control lets you set a reminder to turn the patient. The reminder can be set to occur in 30, 60, 90, or 120 minutes.

1. Press the **Reminder** menu control on the GCI.

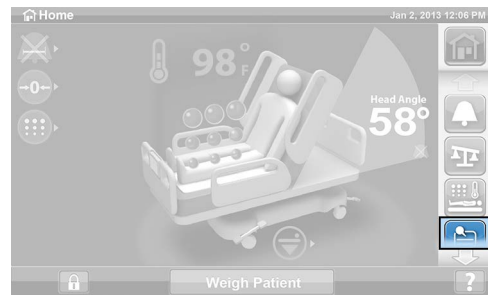

2. Press the applicable time that you want the reminder to occur. Or, press **Off** to turn a previously set reminder off.



3. After the set time expires, the RemindMe message will show on the GCI. Press **Reset** or **Off** as applicable. The GCI will show the Home screen. To reset the reminder, repeat the steps above.

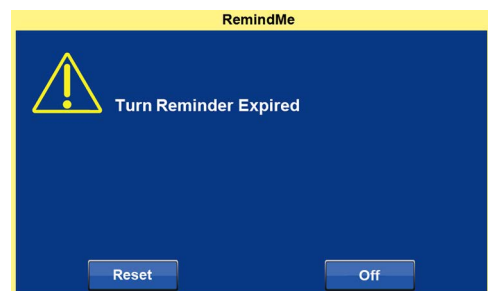

PREFERENCES

Through the Preferences menu control, you can—

- Review the history for the different bed functions.
- Adjust the GCI's date and time.

History

1. Press the **Preferences** menu control on the GCI.

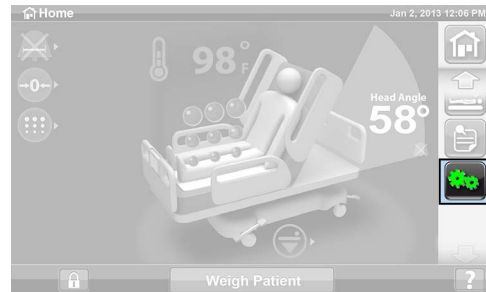

2. Press **History**.

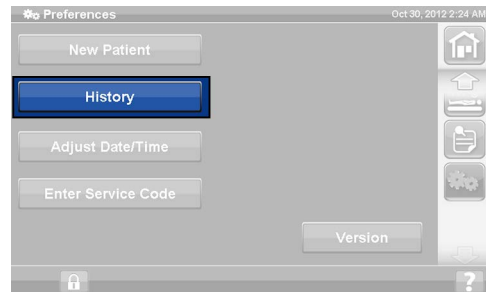

3. Press the control for the applicable function.



- For example, if you pressed **Scale** in Step 3, you would see this screen. Press **History**.

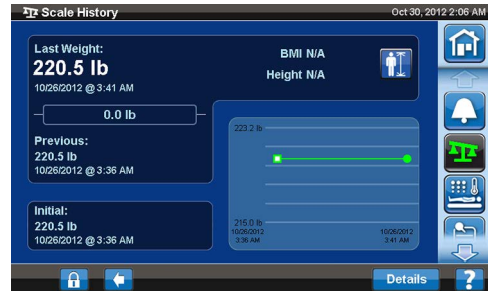

Adjust Date/Time

- Press the **Preferences** menu control on the GCI.

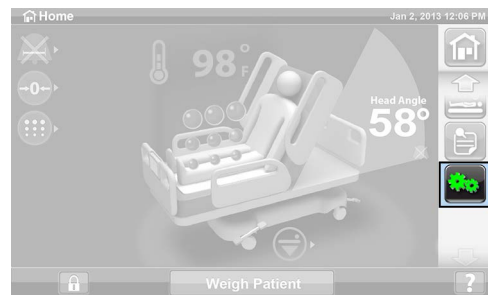

- Press **Adjust Date/Time**.

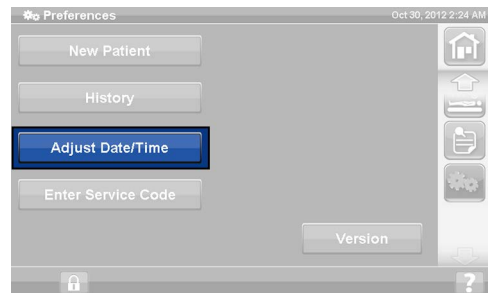

- Press the **Up** and **Down** arrows to adjust the date and time as necessary, and then press **Accept**.

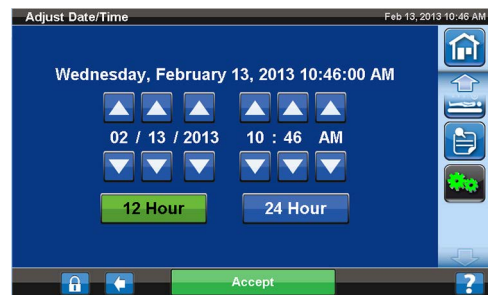

ELECTROCARDIOGRAM AND ELECTROENCEPHALOGRAPH

Electrostatic charges of the fluidizing beads may cause minor interference with electrocardiogram (ECG or EKG) or electroencephalogram (EEG). When you record an ECG, EKG or EEG, press the **Bed Therapy** control to turn off air fluidization.

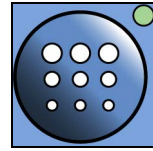

WARNING:

Warning—Before you record an electrocardiogram (ECG or EKG) or electroencephalogram (EEG), make sure that Bed Therapy is **off**. Failure to do so may cause minor interference with the ECG/EKG or EEG recording. Patient injury or equipment damage could occur.

POSITION THE PATIENT



WARNING:

Warning—Make sure that the patient is in the correct position on the bed. Patient injury can occur.

- When you put the patient in the bed, make sure that:
 - The patient's head, shoulders, and back, are supported by the head section of the bed.
 - The patient's buttocks, legs, and feet are on the air fluidized therapy section of the bed.
 - The patient is centered on the bed .
 - The patient's hips are aligned with the hip position locator.



ADJUST THE PATIENT'S POSITION

TURN THE PATIENT FOR SIDE LYING WITH A PILLOW

- With air fluidization on**, pull the filter sheet that is under the patient's lower torso to the side of the bed so that the sheet is loose and moves freely with the patient.



2. Gather the flat bed sheet in close to the patient's shoulder and hip.

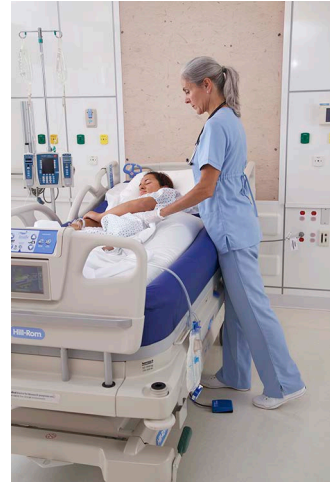

3. Use the flat bed sheet to gently float the patient toward your side of the bed.
4. If possible, slightly bend the patient's leg that is closest to you or cross that leg over the other to assist with the forward turning motion.
5. With the flat bed sheet still gathered close to the patient's shoulder and hip, pull the flat bed sheet upward while you turn the patient away from you into a side-lying position.

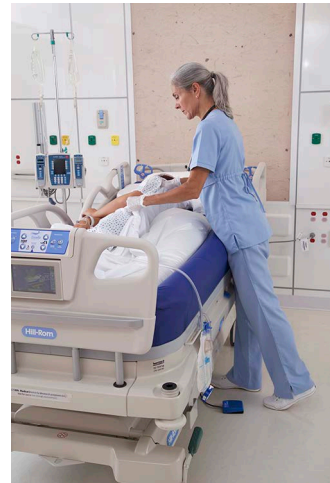

6. When the patient is in the side-lying position, put the pillow behind the patient and then lean the patient back on to the pillow.



TURN THE PATIENT FOR LINEN CHANGES

1. Turn the patient. Refer to "Turn the Patient for Side Lying with a Pillow" on page 61, Step 1 through Step 5.
2. **With air fluidization on**, roll the linen along the patient's body and gently push the roll of dirty linen under the patient and put the clean linen into position as you would on a standard hospital bed.
3. Roll the patient over the clean linen, pull the dirty linen out, and put the clean linen into position.

4. When the linen change is complete, make sure the patient's position is such that the patient's hips are aligned with the hip indicator on the bed.
5. Gently pull the Filter Sheet loosely around the patient's body so that the patient floats optimally in the bead section of the bed.



TURN THE PATIENT FOR BACK, WOUND, AND PERINEAL CARE

1. Remove the **foot control** from its holder, and put it within reach of your foot. Do this so that you can turn air fluidization on or off, as needed, with your foot as you help the patient move into position.

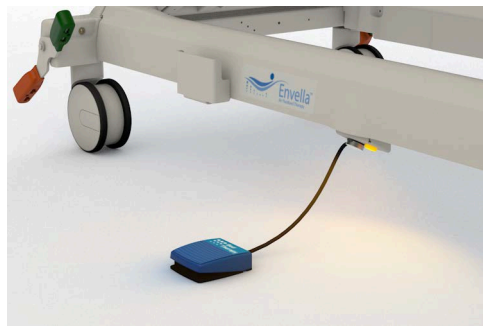

2. Turn the patient. Refer to "Turn the Patient for Side Lying with a Pillow" on page 61, Step 1 through Step 5.
3. When the patient is in the side-lying position, step on the **foot control** to **turn air fluidization off**.



4. As air fluidization stops, use the flat bed sheet to **lift** the patient's hips/buttocks up out of the beads.

NOTE:

The beads will float upward, and the patient will be on "top" of the beads for you to have access to the back and/or wound.

5. For better access to the wound, as you use one hand to lift the patient's hips/buttocks up out of the beads, use your other hand to push down in the desired area of the beads to form an indentation.

NOTE:

With air fluidization off, the beads will hold the patient in the side-lying position.

6. When you have completed the procedure, **turn air fluidization on** (either step on the foot control or press the Bed Therapy control).
7. Make sure the patient's position is such that the patient's hips are aligned with the hip indicator on the bed.
8. Gently pull the Filter Sheet loosely around the patient's body so that the patient floats optimally in the bead section of the bed.



ADJUST THE FEMALE PATIENT'S POSITION FOR CATHETERIZATION

1. Remove the **foot control** from its holder, and put it within reach of your foot. Do this so that you can turn air fluidization on or off, as needed, with your foot as you help the patient move into position.

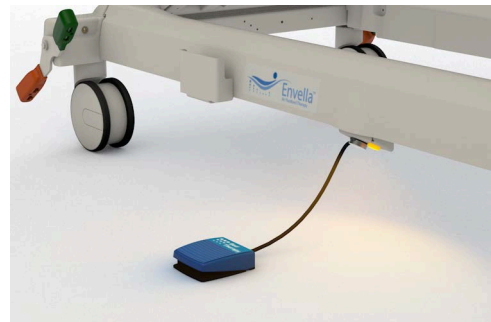

2. Put the patient on her back, and then lower the head section as much as the patient can tolerate.
3. With a person on each side of the bed, gather the flat bed sheet close to the patient's pelvis area.



4. **As you lift the patient's pelvis up out of the beads**, step on the foot control to turn air fluidization off. The beads will float upward, and the patient's pelvis will be on a flat surface for better visualization and access.
5. When you have completed the procedure, turn air fluidization on (either step on the foot control or press the Bed Therapy control).

6. Make sure the patient's position is such that the patient's hips are aligned with the hip indicator on the bed.
7. Gently pull the Filter Sheet loosely around the patient's body so that the patient floats optimally in the bead section of the bed.



ADJUST THE PATIENT'S POSITION FOR BEDPAN USE

1. Turn the patient. Refer to "Turn the Patient for Side Lying with a Pillow" on page 61, Step 1 through Step 5.
2. **With air fluidization on**, press the bedpan sideways into the beads, and then use the flat bed sheet to roll the patient back towards you and on to the bedpan.

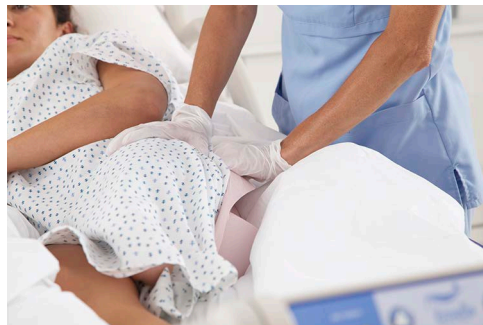

3. When the patient is finished with the bedpan, have a caregiver on each side, and do as follows:
 - a. **With air fluidization on**, have one caregiver hold the bedpan in the beads as the other caregiver gently rolls the patient **off** the bedpan and into a side-lying position.
 - b. Immediately **turn air fluidization off** (either step on the foot control or press the Bed Therapy control).

NOTE:

To get the patient turned further, as air fluidization stops, hold the flat bed sheet **and** the filter sheet to **lift** the patient's hips/buttocks up out of the beads. The beads will float upward and the patient will be on "top" of the beads.

- c. Remove the bedpan.
4. Clean the patient.
 5. **Turn air fluidization on** (either step on the foot control or press the Bed Therapy control).
 6. Make sure the patient's position is such that the patient's hips are aligned with the hip indicator on the bed.

7. Gently pull the Filter Sheet loosely around the patient's body so that the patient floats optimally in the bead section of the bed.



TRANSPORT



WARNING:

To help prevent injury and/or equipment damage, obey these **warnings**:

- **Warning**—The bed is heavy. When a patient is on the bed, use a minimum of two persons to transport the bed.
- **Warning**—During transport, keep hands and feet clear of the wheels. Move the bed only at a slow walk.
- **Warning**—When the bed is unplugged, the cushions will remain inflated for 2 hours, but may not deliver pressures at the therapeutic levels set for the patient. Transport should occur as soon as possible after you unplug the bed, and the bed should be plugged in as soon as transport is complete.
- **Warning**—A patient should **not** remain on the bed with air fluidization not operating for more than two hours.
- **Warning**—During transport, use caution so that the bed does not tip or overbalance.
 - Generally, as the load and bed height increases, the risk of instability goes up.
 - The user and position of accessories may affect stability. Do not overextend IV poles or similar accessories, and do not overload accessories. If there are multiple accessories, distribute them evenly from side to side or head to foot.
 - For inclines and thresholds, approach them as you move forward or backward, instead of sideways.
 - To help prevent overbalance or collision with hidden objects or people, do not make sharp turns at corners and do not turn the bed at high speeds.

**CAUTION:**

To help prevent equipment damage, obey these **cautions**:

- **Caution**—Before you transport the bed, make sure that the power cord, hoses, and other equipment are correctly stowed.
- **Caution**—Before you transport the bed, make sure that the foot controls are stowed in their holders.



- **Caution**—Do not push or pull the bed by IV poles, oxygen tank holders, siderails, or other equipment. Use the headboard or footboard.

The bed is intended to be used to transport patients with the foot end of the bed forward.

TRANSPORT THE BED

1. Adjust the head section to the desired position for the patient's comfort.
2. Adjust the bed to a comfortable height for the transporters.
3. Make sure all siderails are installed and securely locked.
4. Make sure the patient, equipment, and lines are secure within the perimeter of the bed.
5. If the Patient Helper accessory is installed, make sure that it does not impact doorways or ceiling fixtures.
6. Secure oxygen tanks as applicable.
7. Lower the IV poles as necessary so that they do not impact doorways or ceiling fixtures.
8. Unplug the power cord. Use a **blue** cord hook at the head section to stow the cord during transport.
9. Set the brake to **Neutral** or **Steer**.
10. Make sure the casters are in the trailing position.
11. Transport the bed per facility protocol.
12. If it is necessary to transfer the patient from the bed, refer to "Surface Transfer" on page 24.

NOTE:

When the bed is unplugged, the cushions will remain inflated for approximately two hours and air fluidization will not operate. As air fluidization stops, the beads form an imprint around the patient's body surface.

AFTER TRANSPORT

1. Put the bed in its intended location.
2. Set the brake.
3. Plug the bed into an applicable power outlet. If the bed stays unplugged for more than two hours, remove the patient from the bed.
4. Adjust the IV poles to the correct working height.
5. Put oxygen tanks in their holders as applicable.

ACCESSORIES

Part Number	Description
P0820	Patient Helper
195108	Foot support cushion
P007012A	Impervious Sheet
P158A ^a	Infusion support system (ISS) (not available for rent)
P2217A	IV pole (not available for rent)
P276 and P27601	Oxygen tank holder, vertical

a. Adapter bracket P163 must be installed for use of P158A.



WARNING:

To help prevent injury and/or equipment damage, obey these **warnings**:

- **Warning**—Zero the scale before a new patient is put on the bed.
- **Warning**—Whenever new equipment is put on the bed, zero the scale **before** the patient is put on the bed.
- **Warning**—Use accessories from Hill-Rom only.

PATIENT HELPER (P0820)

The Patient Helper can be used to help assist patients with mobility.



WARNING:

To help prevent injury and/or equipment damage, obey these **warnings**:

- **Warning**—Do not remove or install the Patient Helper arm assembly while a patient is in the bed.
- **Warning**—Use correct lifting techniques and/or ask for assistance when you install or remove the Patient Helper.
- **Warning**—Correctly attach the Patient Helper arm assembly; otherwise, it may fall.
- **Warning**—Do not exceed the 77 kg (170 lb) load capacity (safe working load) (pull force) of the Patient Helper arm assembly.

Install

1. Make sure the bed's brake is set and a patient is not in the bed.
2. Lower the bed to its lowest position.



3. Remove the pull pin from the Patient Helper mount on the head-end of the bed.
4. Install the arm assembly into the Patient Helper mount. Make sure the arm assembly is fully inserted in the mount.

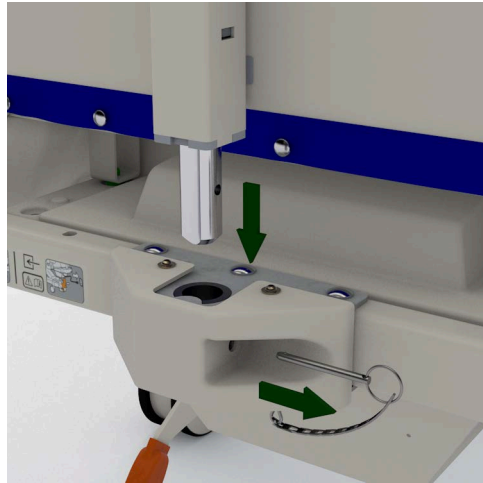

5. Insert the pull pin to hold the Patient Helper arm assembly in position.

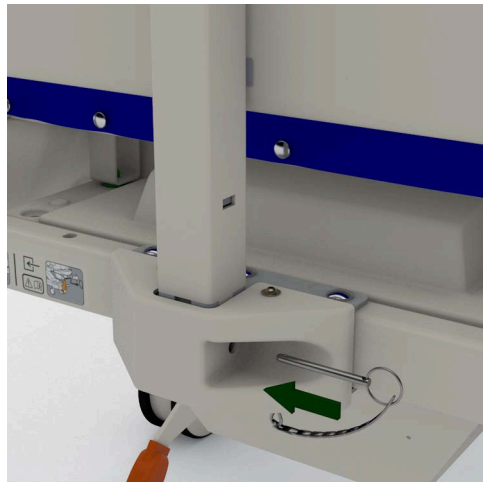

6. Install the horizontal arm into the arm assembly, and insert the pull pin to hold the horizontal arm in position.

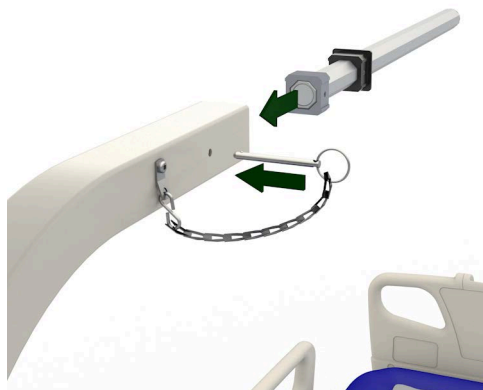

7. Install the clamp of the trapeze handle assembly on to the horizontal arm, and tighten the clamp to attach the trapeze handle assembly to the horizontal arm.



8. Zero the bed scale. Refer to “Zero the Scale” on page 45.

Remove

1. Loosen the clamp that attaches the trapeze handle assembly to the horizontal arm, and remove the trapeze handle assembly from the horizontal arm.
2. Remove the pull pin and horizontal arm from the assembly.
3. Remove the pull pin and arm assembly from the Patient Helper mount.
4. Insert the pull pin into the Patient Helper mount.

FOOT SUPPORT CUSHION (195108)

The foot support cushion helps to provide support and stability for the patient’s feet. Use the foot support cushion per facility protocol.

Install

1. Put the straps through the handles in the footboard, and snap the straps closed.
2. Connect the hose connector that is on the back of the cushion to the connector at the foot end of the air wall.



Remove

1. Disconnect the hose connector that is on the back of the cushion from the connector at the foot end of the air wall.
2. Disconnect the snaps on straps, and remove the cushion from the footboard.

IMPERVIOUS SHEET (P007012A)

The Impervious Sheet is available as an accessory to cover the bead section of the bed. When clinical or Hill-Rom recommends, the Impervious Sheet may be used to block airflow from the bed to the patient. The Impervious Sheet is completely impervious to moisture and air.

To keep the Impervious Sheet in position, tie the sheet straps to the patient restraint holders on the bed.

**WARNING:**

Warning—The Impervious Sheet blocks airflow and will cause a change to Bed Therapy. Use the Impervious Sheet only after clinical or Hill-Rom recommendation. Otherwise, patient injury could occur.

INFUSION SUPPORT SYSTEM (P158A)

The ISS consists of a movable and adjustable IV pole. The pole supports IV pumps or bags in a vertical orientation and raises or lowers the pumps or bags with respect to the system frame.

The head end of the system has attaching points for two mobile ISS poles. Each pole can support one infusion pump plus two liters of intravenous solution.

Before you install the ISS pole (P158A), you must install the P163 ISS socket adapter.

**WARNING:**

To help prevent injury and/or equipment damage, obey these **warnings**:

- **Warning**—Do not exceed the 9 kg (20 lb) load capacity (safe working load) of the infusion support system (ISS) pole.
- **Warning**—Correctly attach the ISS pole; otherwise, it may fall.
- **Warning**—Uneven loading of the ISS pole could cause the contents to fall.
- **Warning**—When you lower the upper section of an ISS pole, always hold the upper section of the pole while you loosen the collet.

NOTE:

Make sure when you mount infusion pumps on an IV pole that the pumps do not interfere with the head section articulation.

IV POLE (P2217A)

The IV pole is a removable, telescopic pole that installs in any of the equipment sockets.

Install

Insert the IV pole vertically into any of the equipment sockets at either the head end or foot end of the bed.

Remove

Pull the IV pole out from the equipment socket.





WARNING:

To help prevent injury and/or equipment damage, obey these **warnings**:

- **Warning**—Do not exceed the 11 kg (25 lb) load capacity (safe working load) of the IV pole.
- **Warning**—Correctly attach the IV pole; otherwise, it may fall.
- **Warning**—Uneven loading of the IV pole could cause the contents to fall.
- **Warning**—When you lower the upper section of an IV pole, always hold the upper section of the pole before you pull the release knob.
- **Warning**—Install the IV pole in an equipment socket only. See “Equipment Sockets” on page 17.

OXYGEN TANK HOLDER, VERTICAL (P276 AND P27601)

The oxygen tank holder holds one **E** size oxygen tank with a regulator. The mount location lets the affixed oxygen tank holder pivot. The safe working load of the oxygen tank holder is 14 kg (30 lb).



WARNING:

To help prevent injury and/or equipment damage, obey these **warnings**:

- **Warning**—Failure to correctly attach the oxygen tank holder could cause it to drop.
- **Warning**—Use caution when you put the oxygen tank holder in position. Keep it away from the moving parts.

Install

1. Install the mounting bar vertically into any of the equipment sockets at either the head end or foot end of the bed.
2. Put the oxygen tank in the oxygen tank holder.
3. Tighten the holder thumbscrew to keep the oxygen tank in position.
4. Make sure of these:
 - The holder is secure in its position.
 - The holder will not interfere with the bed’s moving parts.

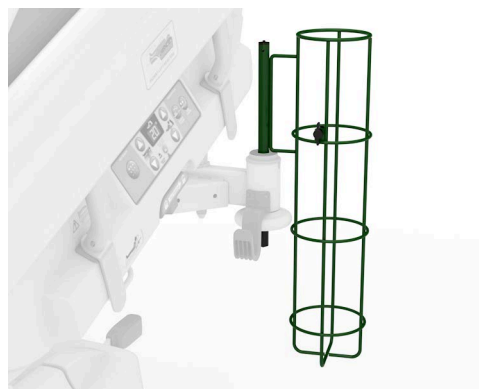

NOTE:

Make sure that when you put an oxygen tank in the holder that the tank does not interfere with the head section articulation.

Remove

1. Loosen the thumbscrew that holds the oxygen tank tight in the oxygen tank holder.
2. Lift the oxygen tank out of the oxygen tank holder.
3. Lift up on the oxygen tank holder, and remove it from the equipment sockets.

DETACHABLE PARTS

Description
Head and intermediate siderails
Headboard
Foot control



WARNING:

Warning—Use detachable parts from Hill-Rom only. Otherwise, patient injury or equipment damage could occur.

CLEANING AND DISINFECTING

When needed, the hard surfaces and covers of the bed may be cleaned and disinfected during patient use.

NOTES:

- You may remove heavy soiling from the Filter Sheet, but you can **not** disinfect it. For disinfection, contact Hill-Rom.
- The microspheres can not be decontaminated without special equipment. For decontamination, contact Hill-Rom.
- Spot cleaning may not **remove** all stains; however, stains do not affect the cleanliness of the product.



WARNING:

To help prevent injury and/or equipment damage, obey these **warnings**:

- **Warning**—The potential for electrical shock exists with electrical equipment. Failure to follow facility protocol could cause death or serious injury.
- **Warning**—Do not reuse wiping material for multiple steps or on multiple products.
- **Warning**—Harmful cleaning solutions may cause skin rash and/or irritation upon contact. Follow the manufacturer's instructions found on the product label and Safety Data Sheet (SDS).
- **Warning**—Lift and move items correctly. Do not twist, and seek assistance when necessary. Make sure the bed is at a correct height to lift items off the bed.
- **Warning**—Fluid spills on to the bed electronics could cause a hazard. If such a spill occurs, unplug the bed, and remove it from service. When fluid spills occur outside of what is seen in normal use, immediately do as follows:
 - a. Unplug the bed from its power source.
 - b. Remove the patient from the bed.
 - c. Clean the fluid spill from the bed system.
 - d. Have maintenance examine the system completely.
 - e. Do not put the bed back into service until it is completely dry, tested, and found to be safe to operate.



CAUTION:

To help prevent equipment damage, obey these **cautions**:

- **Caution**—Do not steam clean or power wash the bed. Pressure and excessive moisture can damage the protective surfaces of the bed and its electrical components.
- **Caution**—Do not use harsh cleansers/detergents, heavy duty grease removers, solvents such as toluene, xylene, or acetone, and do not use scouring pads (you may use a soft bristle brush).
- **Caution**—Do not use bleach as your primary everyday cleaner/disinfectant.

RECOMMENDATIONS

For proper cleaning and disinfection, staff members should be trained.

The **trainer** should carefully read the instructions and follow them when the **trainee** is being trained.

The trainee should:

- Be given time to read the instructions and to ask any questions.
- Clean and disinfect the product while the trainer supervises. During, and/or after this process, the trainer should correct the trainee of any differences from the instructions for use.

The trainer should supervise the trainee until the trainee can clean and disinfect the bed as instructed.

Hill-Rom recommends to clean and disinfect the bed before first patient use, between patient use, and regularly during extended patient stays.

Some fluids used in the hospital environment, such as iodophor and zinc oxide creams, can cause permanent stains. Remove temporary stains by wiping vigorously with a lightly-dampened wiping cloth.

CLEANING AND DISINFECTION

Cleaning and disinfection are distinctly different processes. **Cleaning** is the physical removal of visible and non-visible soil and contaminants. **Disinfection** is intended to kill microorganisms.

Table 1 below summarizes the approved cleaners/disinfectants for use along with the associated contact time for disinfection.

Table 1: Approved Cleaners/Disinfectants

Cleaner/Disinfectant	Recommended for Routine Cleaning and Disinfection	Recommended for Disinfection against Clostridium Difficile (C.Diff)	Maintain Wetness (Disinfection Contact Time)
Wex-Cide™ Germicidal Detergent ready-to-use	Yes	No	10 minutes
Virex® II 256	Yes	No	10 minutes
OxyCide® Daily Disinfectant Cleaner	Yes	Yes	3 minutes
Oxivir TB	Yes	No	10 minutes
CaviCide	Yes	No	3 minutes
Clorox HealthCare® Bleach Germicidal Cleaner ready-to-use	No*	Yes	5 minutes
Clorox HealthCare® Bleach Germicidal Wipes	No*	Yes	3 minutes

*Bleach is not recommended as the primary cleaner/disinfectant.

Remove any disinfectant residue prior to and after the use of bleach with a new or clean cloth/wipe soaked in tap water.

When you perform the detailed cleaning steps, please note the following:

- A reusable or disposable microfiber cloth or a Clorox HealthCare® Bleach Germicidal Wipe is recommended as the wiping cloth.
- Always replace the wiping cloth when visibly soiled.
- Always replace the wiping cloth between steps (spot clean, clean, and disinfect).
- Always use Personal Protective Equipment (PPE).
- Adjust the bed position, siderails, headboard, and footboard as needed for ease of cleaning and disinfection.

Prepare the Bed for Cleaning and Disinfecting

- Unplug the bed.

STEP 1: Cleaning

- a. As necessary, first remove visible soil from the bed using a wiping cloth soaked with an approved cleaner/disinfectant (see "Table 1: Approved Cleaners/Disinfectants" on page 74).
 - Give special attention to seams and other areas where soil may accumulate.
 - A soft bristle brush may be used to loosen hardened soil.
 - Use as many wiping cloths as needed to remove the soil.

It is important to remove all visible soil from all areas before continuing to remove non-visible soil.

- b. To remove heavy soiling from the **filter sheet**, do as follows:
 - Spot clean per the instructions on the facility approved mild soap diluted with water.
 - Examine the filter sheet for any remaining soil. If there is remaining soil, repeat the spot cleaning until you have removed all visible soil.
 - Let the spot dry while air fluidization is **on**.

NOTE:

If the **filter sheet** requires full cleaning or disinfection, contact Hill-Rom for a replacement. The patient will need to be removed from the bed to replace the filter sheet.

- c. With a new or clean wiping cloth soaked in an approved cleaner/disinfectant, use firm pressure to wipe all surfaces of the bed. Use a new or clean wiping cloth as often as necessary. Make sure the following items are cleaned:
 - Siderails
 - Headboard, footboard, and under the GCI
 - Areas between the footboard and mattress, headboard and mattress, and siderails and mattress
 - Upper frame
 - Base frame
 - Power cord
 - Patient pendant (handheld remote) and pendant cord
 - Accessories

STEP 2: Disinfection

- a. With a new or clean wiping cloth soaked in an approved cleaner/disinfectant, use light pressure to wipe all exterior surfaces of the bed previously cleaned.
- b. Make sure all surfaces **remain wet with the cleaner/disinfectant** for the **specified contact time**. **Re-wet** surfaces with a new or clean wiping cloth as necessary. See "Table 1: Approved Cleaners/Disinfectants" on page 74 for the contact time.

NOTES:

- If bleach is used with another cleaner/disinfectant, use a new or clean cloth/wipe soaked in tap water to remove any disinfectant residue prior to and after the bleach application.
- If the **filter sheet** requires full cleaning or disinfection, contact Hill-Rom for a replacement. The patient will need to be removed from the bed to replace the filter sheet.
- For a special clinical need that may require disinfecting the sheet or changing the microspheres during a single patient's use, contact Hill-Rom prior to placing the patient.

PROCESS THE BED AFTER PATIENT USE



WARNING:

Warning—To reduce a contamination risk, **do not** remove the bed from the patient room until you have completed the processing steps.

NOTE:

The bed should be removed from the patient room before terminal reprocessing of the room. Do not return a used bed to a patient room that has had terminal reprocessing.

1. Use the blue cover supplied by Hill-Rom to cover the bed.
2. Clean and disinfect exposed surfaces according to the procedures listed above.
3. The bed may now be removed from the patient room.

MAINTENANCE



WARNING:

Warning—Only Hill-Rom authorized persons should service the bed. Service done by unauthorized persons could cause injury or equipment damage.

NOTE:

This is a rental only product; there are no user replaceable parts. For replacement parts, call Hill-Rom at 800-638-2546.

SERVICE CALLS

When you call Hill-Rom about your bed, be prepared to give the serial number from the product identification label. The location of the product identification label is shown in the illustration.

When you give the serial number, the Hill-Rom representative can identify your bed and give you the information you need more quickly.

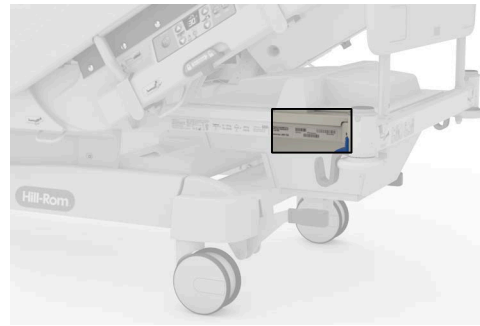

TROUBLESHOOTING



WARNING:

Warning—Only Hill-Rom authorized persons should service the bed. Service done by unauthorized persons could cause injury or equipment damage.



WARNING:

Warning—To help prevent patient injury, remove the patient from the bed and call Hill-Rom at 800-638-2546 if any of these occur—

- The bed does not respond to user controls as described in this manual.
- “Notify Hill-Rom” shows on the GCI.
- There is an electrical or mechanical problem.
- Air fluidization is sluggish or uneven, and **not** caused by blankets and pillows on the bed or recent fluid ingress into the beads.

STORAGE AND HANDLING

For storage and handling, contact Hill-Rom.

SPECIFICATIONS

Product Revision

Model	Description
P0819A	Initial release

Bed Specifications

Feature	Dimension
Maximum length with and without accessories	92.5" (235.0 cm)
Maximum width with siderails removed or installed	40" (101.6 cm)
Maximum height with accessories and options when the bed is in its lowest position	78" (198.0 cm)

Feature	Dimension
Minimum distance between the inside of the headboard and inside of the footboard	83.5" (212.2 cm)
Minimum width of the bead section	19" (48.3 cm)
Minimum length of the bead section	45" (114 cm)
Minimum bed frame ground clearance	3" (76 mm)
Hilow travel range	22" to 31.5" (56 cm to 80 cm)
Head elevation range	0° to 60°
Head section panel height at lowest position with the bed flat	22" (55.9 cm)
Patient weight range	70 lb to 350 lb (32 kg to 159 kg)
Safe working load	450 lb (204 kg)
Total bed weight with the safe working load	1874 lb (850 kg)
Sound pressure level (per IEC 60601-2-52)	
Maximum during normal fault free operation, excluding the actuator	65 dBA
Maximum during short term/impulsive operation	85 dBA
Sound pressure level (per IEC 60601-1-8)—medium priority alarm signal	74 dBA
Bead temperature control range	86°F to 100°F (30°C to 38°C)
Bead temperature comfort range	88°F to 94°F (31°C to 34°C)

Environmental Conditions for Transport and Storage

Condition	Range
Temperature	-20°F to 140°F (-29°C to 60°C)
Relative humidity	15% to 90%
Pressure	50.0 kPa to 106.0 kPa

Environmental Conditions for Use

Condition	Range
Ambient operating temperature range ^a	
With air fluidization temperature setpoint between 86°F and 100°F (30°C and 37.8°C)	72°F to 78°F (22.2°C to 25.6°C)
With air fluidization temperature setpoint between 86°F and 98°F (30°C and 36.7°C)	70°F to 71°F (21.1°C to 21.7°C)
With air fluidization temperature setpoint between 86°F and 96°F (30°C and 35.6°C)	68°F to 69°F (20°C to 20.6°C)
Relative humidity	20% to 75%
Pressure	82.8 kPa to 106 kPa
Altitude	1676 m (5500 ft)

a. Variation in these temperature specifications could be caused by humidity, restricted air circulation from blankets and pillows on the bed, or recent fluid ingress into the beads.

Power Requirement

Condition	Range
Rated voltage	120 V AC, 60 Hz
Rated current	10 A
Mode of operation	2 minutes ON / 18 minutes OFF

There are no user accessible fuses. Refer to the *Envella® Air Fluidized Therapy System Service Manual* (194345) for fuse ratings and replacement procedures.

Applied Parts in Accordance with IEC60601-1

Applied Part	Applied Part
Siderails (not including the posts)	Footboard (not including the posts)
Headboard (not including the posts)	Support surface (coverlet, filter sheet, air wall cover, foot cushion)
Pendant (hand control)	

Classification and Standards

Classification	Standard
Technical and quality assurance standards	IEC 60601-1 ANSI/AAMI ES60601-1 IEC 80601-2-35 IEC 60601-1-8 IEC 60601-1-2 IEC 60601-2-52 CAN/CSA C22.2 No. 60601-1
Equipment classification per IEC 60601-1	Class I equipment
Degree of protection against electric shock	Type B
Degree of protection against ingress of water	IPX4
Degree of protection against the presence of flammable anesthetic mixtures	Not for use with flammable anesthetics
Application Environments (per IEC60601-2-52)	Intensive/critical care (environment 1) Acute care (environment 2) Long term care (environment 3) Outpatient/ambulatory care (environment 5)

Electromagnetic Emissions Guidance



WARNING:

To help prevent injury and/or equipment damage, obey these **warnings**:

- **Warning**—The P0819 should not be used adjacent to or stacked with other electrical equipment. If adjacent or stacked use is necessary, observe the P0819 and the other electrical equipment to make sure they operate as intended.
- **Warning**—Use of accessories, transducers, and cables other than those specified or provided by the manufacturer of this equipment could result in increased electromagnetic emissions or decreased electromagnetic immunity of this equipment and result in improper operation.
- **Warning**—Portable RF communications equipment (including peripherals such as antenna cables and external antennas) should be used no closer than 30 cm (12") to any part of the P0819, including cables specified by the manufacturer. Otherwise, degradation of the performance of this equipment could result.



CAUTION:

Caution—This device meets all requirements for electromagnetic compatibility per IEC 60601-1-2. It is unlikely that the user will encounter problems with this device because of inadequate electromagnetic immunity. However, electromagnetic immunity is always relative, and standards are based on anticipated environments of use. If the user observes unusual device behavior, particularly if such behavior is intermittent and associated with nearby use of radio or TV transmitters, cell phones, or electro-surgical equipment, this could be an indication of electromagnetic-interference. If such behavior occurs, the user should try to move the interfering equipment further from this device.

This device is intended for use in professional healthcare facility environments (intensive/critical care, acute care, long-term care, outpatient care), except for near active high frequency surgical equipment and the radio frequency shielded room of a medical equipment system for magnetic resonance imaging, where the intensity of the electromagnetic disturbances is high.

Make sure the P0819 operates correctly when it is used near other electronic devices. Portable and mobile radio frequency (RF) communications equipment can affect electrical equipment.

Medical equipment needs special precautions in regard to electromagnetic compatibility (EMC) and needs to be installed and put into service according to the EMC information supplied in the tables that follow.

Guidance and Manufacturer's Declaration—Electromagnetic Emissions		
The P0819 is intended for use in the electromagnetic environment specified below. The customer or the user of the model P0819 should make sure it is used in such an environment.		
Emissions Test	Compliance	Electromagnetic Environment—Guidance
RF emissions CISPR 11	Group 1	The P0819 uses RF energy only for its internal functions. Therefore, its RF emissions are low and are not likely to cause any interference in nearby electronic equipment.

Guidance and Manufacturer's Declaration—Electromagnetic Emissions		
The P0819 is intended for use in the electromagnetic environment specified below. The customer or the user of the model P0819 should make sure it is used in such an environment.		
Emissions Test	Compliance	Electromagnetic Environment—Guidance
RF Emissions CISPR 11	Class A	NOTE: The EMISSIONS characteristics of this equipment make it suitable for use in industrial areas and hospitals (CISPR 11 class A). If it is used in a residential environment (for which CISPR 11 class B is normally required) this equipment might not offer adequate protection to radio-frequency communication services. The user might need to take mitigation measures, such as relocating or re-orienting the equipment.
Harmonic Emissions IEC 61000-3-2	Not applicable	
Voltage Fluctuations/ Flicker Emissions IEC 61000-3-3	Not applicable	

Electromagnetic Immunity Guidance

Guidance and Manufacturer's Declaration - Electromagnetic Immunity			
The P0819 is intended for use in the electromagnetic environment specified below. The customer or the user of the P0819 should make sure it is used in such an environment.			
Immunity Test	IEC 60601-1-2 Test Level	Compliance Level	Electromagnetic Environment—Guidance
Electrostatic Discharge (ESD) IEC 61000-4-2	± 8 kV Contact ± 2 kV, ± 4 kV, ± 8 kV, and ± 15 kV Air	± 8 kV Contact ± 2 kV, ± 4 kV, ± 8 kV, and ± 15 kV Air	Floors should be wood, concrete, or ceramic tile. If floors are covered with synthetic material, the relative humidity should be at least 30%.
Electrical Fast Transient/Burst IEC 61000-4-4	± 2 kV (100 kHz repetition frequency) for Power Supply Lines	± 2 kV (100 kHz repetition frequency) for Power Supply Lines	Mains power quality should be that of a typical hospital environment.
Surge IEC 61000-4-5	± 1 kV Line(s) to Line(s) ± 2 kV Line(s) to Ground	± 1 kV Line(s) to Line(s) ± 2 kV Line(s) to Ground	Mains power quality should be that of a typical hospital environment.
Voltage dips IEC 61000-4-11	0% U_T : 0.5 cycle At 0°, 45°, 90°, 135°, 180°, 225°, 270°, and 315°	0% U_T : 0.5 cycle At 0°, 45°, 90°, 135°, 180°, 225°, 270°, and 315°	Mains power quality should be of a typical hospital environment. If the user of the P0819 requires continued operation during power mains interruption, it is recommended that the P0819 be powered from an uninterruptible power supply.
	0% U_T : 1 cycle and 70% U_T : 30 cycles Single phase: at 0° (See Note)	0% U_T : 1 cycle and 70% U_T : 30 cycles Single phase: at 0° (See Note)	
Voltage interruptions IEC 61000-4-11	0% U_T : 300 cycles	0% U_T : 300 cycles	
Power Frequency Magnetic Fields IEC 61000-4-8	30 A/m 60 Hz	30 A/m 60 Hz	Power frequency magnetic fields should be at levels characteristic of a typical location in a typical hospital environment.
Note: U_T is the AC mains voltage prior to application of the test level.			

Electromagnetic Immunity Guidance

Guidance and Manufacturer's Declaration - Electromagnetic Immunity			
The P0819 is intended for use in the electromagnetic environment specified below. The customer or the user of the P0819 should make sure it is used in such an environment.			
Immunity Test	IEC 60601-1-2 Test Level	Compliance Level	Electromagnetic Environment—Guidance
Conducted RF IEC 61000-4-6	3 V 0.15 MHz - 80 MHz 6 V in ISM bands between 0.15 MHz and 80 MHz 80% AM at 1 kHz	3 V 0.15 MHz - 80 MHz 6 V in ISM bands between 0.15 MHz and 80 MHz 80% AM at 1 kHz	<p>Field strengths from fixed RF transmitters, as determined by an electromagnetic site survey^b, should be less than the compliance level in each frequency range.</p> <p>Interference may occur in the vicinity of equipment marked with this symbol.</p> <div style="text-align: center;">  </div>
Radiated RF IEC 61000-4-3	3 V/m 80 MHz to 2.7 GHz 80% AM at 1 kHz	10 V/m ^a 80 MHz to 2.7 GHz 80% AM at 1 kHz	
<p>Note: These guidelines may not apply in all situations. Electromagnetic propagation is affected by absorption and reflection from structures, objects and people.</p>			

a. Deviation - tested at higher levels per IEC 80601-2-35.

b. Field strengths from fixed transmitters, such as base stations for radio (cellular/cordless) telephones and land mobile radios, amateur radio, AM and FM radio broadcast and TV broadcast cannot be predicted theoretically with accuracy. To assess the electromagnetic environment due to fixed RF transmitters, an electromagnetic site survey should be considered. If the measured field strength in the location in which the P0819 is used exceeds the applicable RF compliance level above, the P0819 should be observed to verify normal operation. If abnormal performance is observed, additional measures may be necessary, such as reorienting or relocating the P0819.

IMMUNITY to Proximity Fields from Radio Frequency Wireless Communications Equipment						
In addition to the Radiated RF IEC 61000-4-3 as shown in the table above, the P0819 has been tested as specified in the table below.						
Test Frequency (MHz)	Band (MHz)	Service	Modulation	Maximum Power (W)	Distance (m)	Immunity Test Level (V/m)
385	380–390	TETRA 400	Pulse modulation 18 Hz	1,8	0,3	27
450	430–470	GMRS 460, FRS 460	FM \pm 5 kHz deviation 1 kHz sine	2	0,3	28
710	704–787	LTE Band 13,17	Pulse modulation 217 Hz	0,2	0,3	9
745						
780						
810	800–960	GSM 800/900, TETRA 800, iDEN 820, CDMA 850, LTE Band 5	Pulse modulation 18 Hz	2	0,3	28
870						
930						
1720	1700–1990	GSM 1800; CDMA 1900; GSM 1900; DECT; LTE Band 1,3, 4,25; UMTS	Pulse modulation 217 Hz	2	0,3	28
1845						
1970						
2450	2400-2570	Bluetooth, WLAN, 802.11 b/g/n, RFID	Pulse modulation 217 Hz	2	0,3	28
5240	5100–5800	WLAN 802.11 a/n	Pulse modulation 217 Hz	0,2	0,3	9
5500						
5785						

